

**Falk™ Quadrive® Shaft Mounted Drive | Easiest Off, Easiest On, Guaranteed
(Imperial-Inch)**

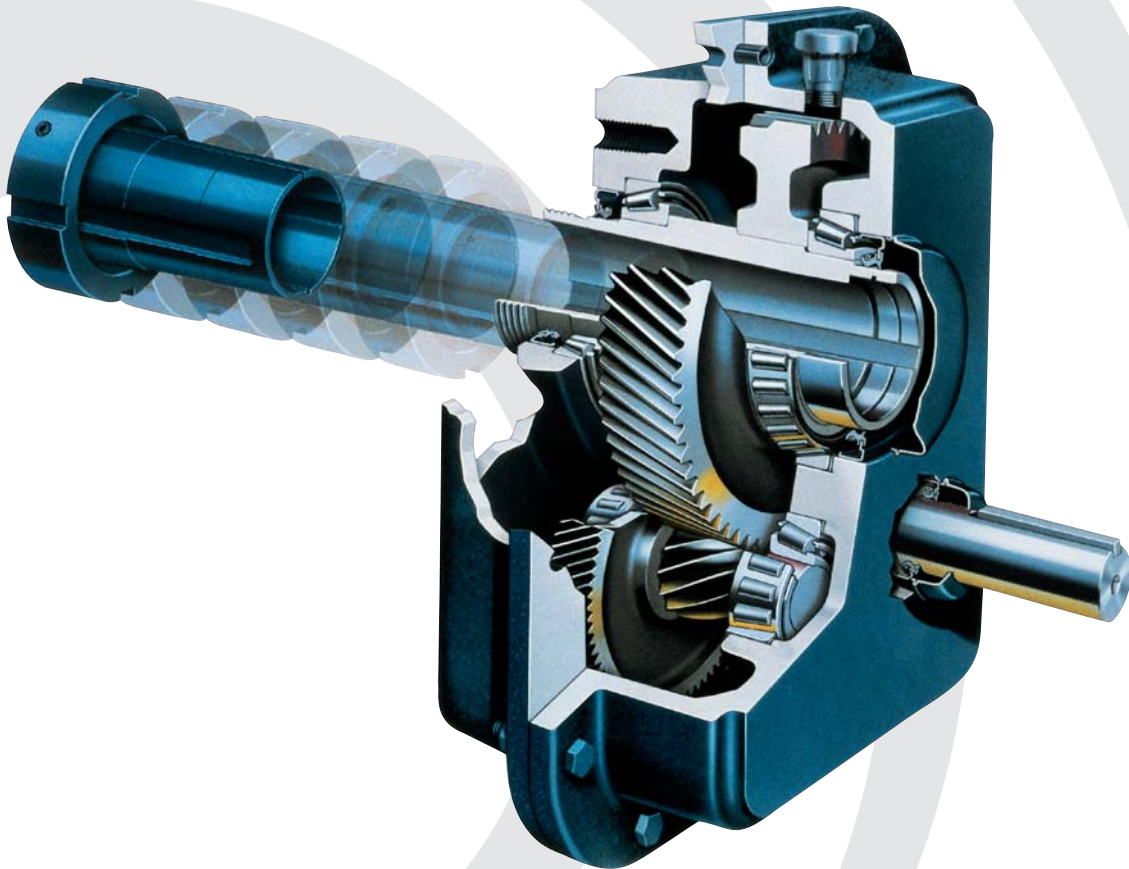



STOP DODGING THE ISSUE

With the new Falk 5000 Series Quadrive, you don't have to turn a blind eye to drive removal issues. It's a simple fact. The heavy duty, shaft-mounted Falk Quadrive features a completely unique design that makes it the easiest, quickest shaft-mounted drive to install and remove.

Quadrive is built to stand up to continuous rough duty. High temperature Viton® seals are standard. And now, with new higher ratings, you may be able to downsize the drive, saving money right up front.

The Falk TA Taper® Bushing design makes sure that drive removal is not only simple, but won't damage the drive, or driven equipment. You don't need extra time. You don't need extra tools. And you're assured safe, worry-free operation.

In a game where there are so few sure things, Falk Quadrive is the right shot to take.

The TA Taper Bushing. Easiest On. Easiest Off

The torque-assist taper bushing makes installation and removal easy. It eliminates binding found with twin-taper and single-flanged bushings.

Concentric operation minimizes wobble, even on worn shafts.

The quill cover keeps contaminants out and protects the outboard shaft seal.

The inboard bushing location minimizes sheave overhang, saving high-speed bearings.

Minimal shaft engagement is required for retrofits.

Lifetime Removal Guarantee

Due to the unique properties of the TA Taper® Bushing, Quadrive is guaranteed to come off the shaft, regardless of length of service or operating conditions, or we'll replace it FREE. That's a promise no other shaft-mounted drive can make.

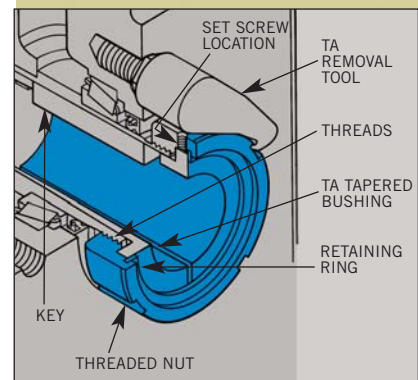

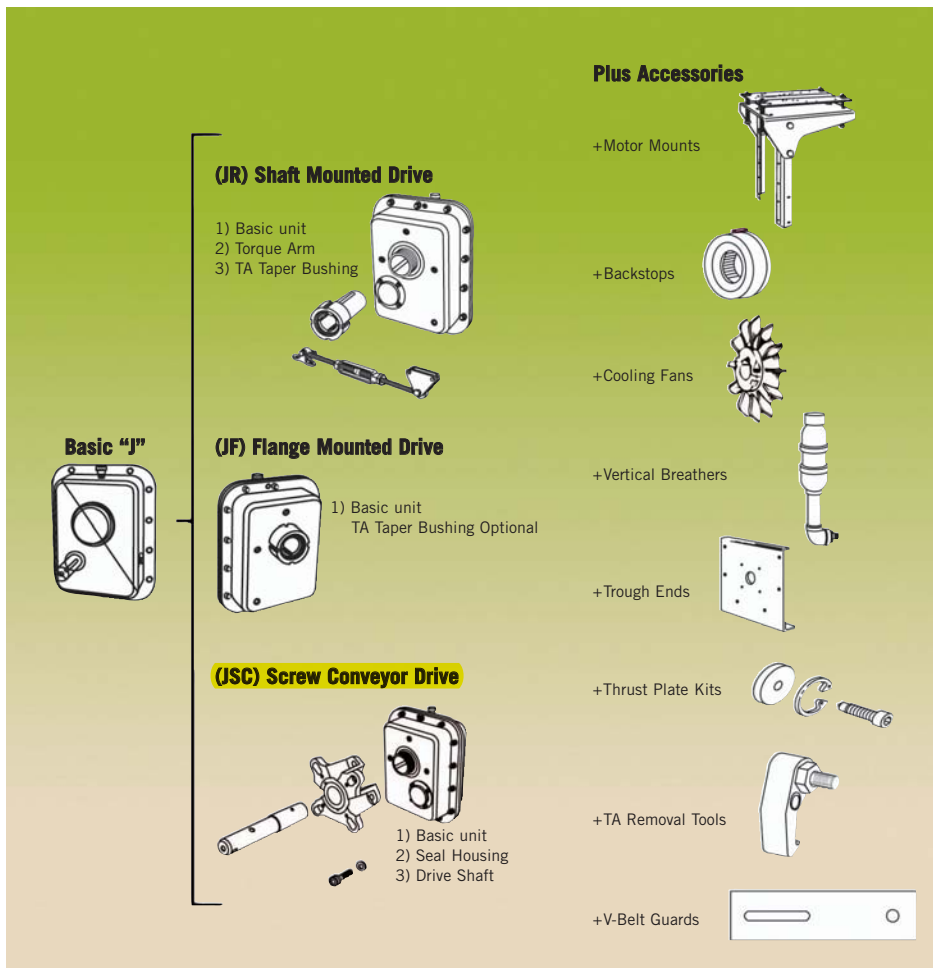

Falk Quadrive Features

Standard Bearings and Viton® Seals: Replacement downtime is minimized with locally available bearings and seals. Manufacturers' numbers are published.

Severe Duty, Grease-Purged Viton Seals: Handle high temperatures, prevent leakage, and ultimate drive failure. Grease barrier traps abrasive contaminants before they can groove the shaft or enter the gear drive.

Long Life Gearing: Quadrive's helical design features high hardness, surface finished teeth with a wider face for maximum load carrying capacity.

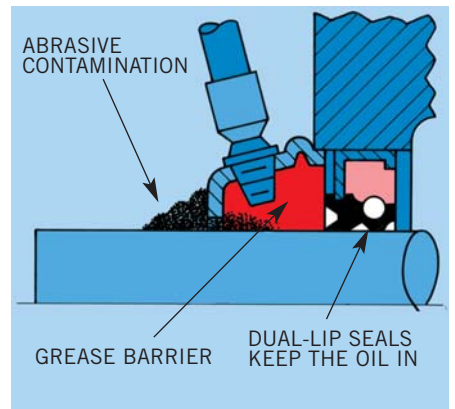

Off-the-Shelf Availability

Whatever your application, Falk Quadrive offers a shaft-mounted solution. Eleven sizes, with 25 to 160 mm (1 to 6 1/2") bushing bores, are available with power ratings up to 224kW (300 HP), 40 675 Nm (360,000 lb.-in.) output. Output from 5 to 350 RPM.

Horizontal/vertical mounting. And the Falk Quadrive serves a whole world of applications with metric or inch output shaft bushings, and motor mounts to suit NEMA and IEC requirements.

Rexnord distributors stock the Quadrive with modular components locally, in popular sizes, and with accessories. Regional distribution centers offer additional drives and parts. So when we say "off the shelf," we mean it.

A Full Line of Accessories

A complete accessory package includes V-belt guards, torque arms, motor mounts, backstops, cooling fans and other time and money saving options.

3-Year Heavy-Duty Warranty

Quadrive is backed by the industry's first standard 3-year warranty, providing full "shaft-to-shaft" protection on all Quadrive components - including bearings and seals.

QUADRIVE Shaft-Mounted Drives Selection Guide

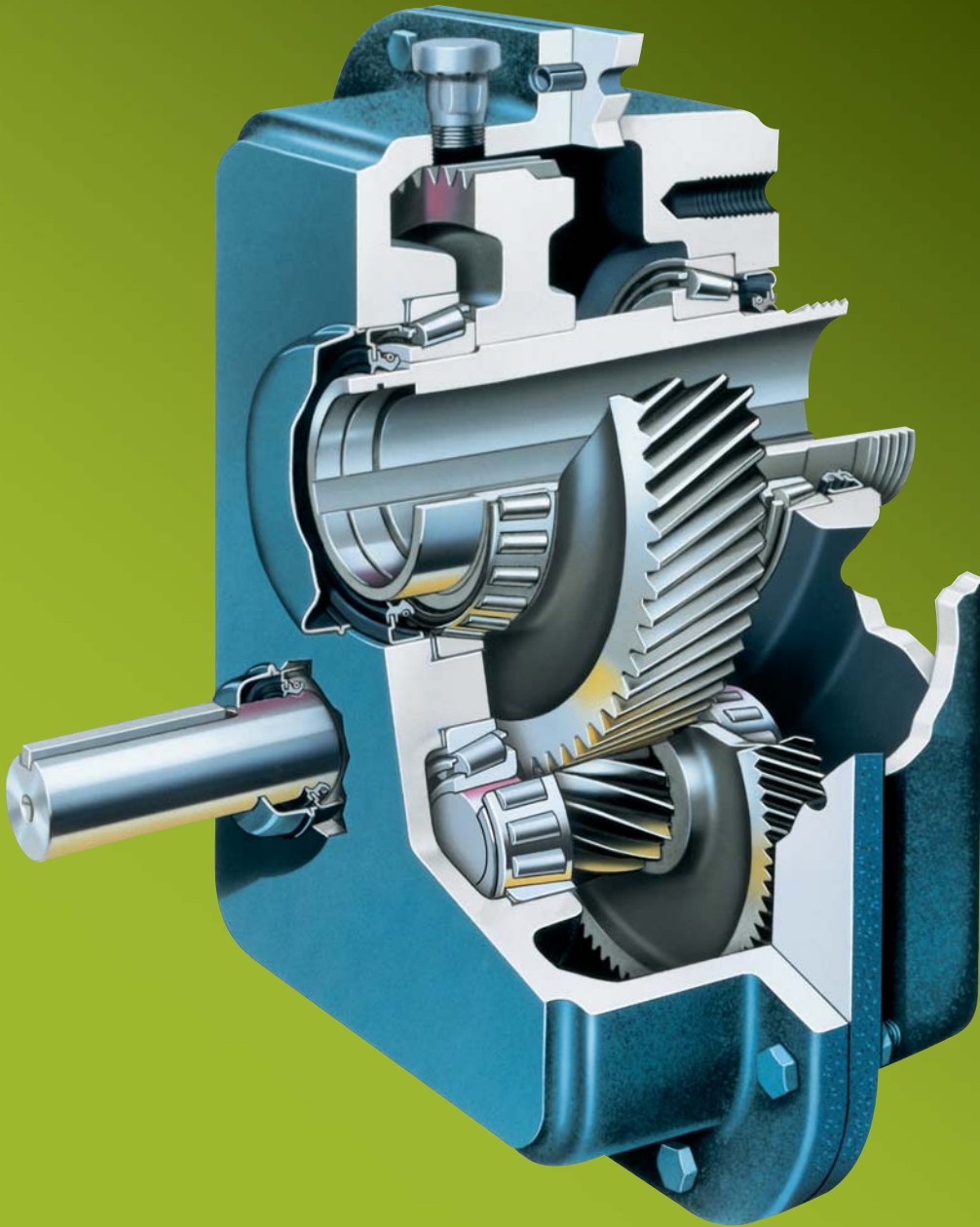

Selection Guide 371-110, May 2006

Table of Contents

Basic Information & Conditions Affecting Selections	5-6
How to Select & Order	7-8
Load Classifications	9
Class I, II & III Selection Tables	10-12
Engineering Data	13-15
5107JR, JF & JSC Dimensions & Part Numbers	16-17
5115JR, JF & JSC Dimensions & Part Numbers	18-19
5203JR, JF & JSC Dimensions & Part Numbers	20-21
5207JR, JF & JSC Dimensions & Part Numbers	22-23
5215JR, JF & JSC Dimensions & Part Numbers	24-25
5307JR, JF & JSC Dimensions & Part Numbers	26-27
5315JR, JF & JSC Dimensions & Part Numbers	28-29
5407JR, JF & JSC Dimensions & Part Numbers	30-33
5415JR & JF Dimensions & Part Numbers	34-35
5507JR & JF Dimensions & Part Numbers	36-37
5608JR & JF Dimensions & Part Numbers	38-40
Trough End Dimensions & Part Numbers	41
Stainless Steel Drive Shafts & Part Numbers	41
Taper Conversion Bushing (TCB) Kits & Part Numbers	41
Nominal Sheave Ratios & V-Belts	42
V-Belt Guard Selections	43-45
Electric Fan Dimensions & Part Numbers	46-47
Motor Mount Shaft Centers & Motor Frame Sizes	48
Accessories/Options	49
Suggested Drive Arrangement—Non Falk Motor Mount	50



Falk Factory Warranty We're so confident in the performance and reliability of our latest generation of Falk heavy-duty products that we're backing this comprehensive offering with the best standard warranty in the business. Our full, 3-year Heavy-Duty Warranty provides "shaft-to-shaft" protection on all Falk components — including bearings and seals. It's an industry first... and one more powerful reason why Falk is your ultimate bottom-line gear drive and coupling value.★

★ Warranty extends for 3 years from date of shipment. Does not apply to Falk Omnibox, Ultramite, Fluid Couplings, Renew and spare parts. Warranty applies to Steelflex and Lifelign couplings with the use of Falk Long Term grease.

Basic Information

Safety Notes

Falk Gear Drives — The Falk name on the gear drive is the purchaser's assurance that the drive was engineered, rated and manufactured to sound design practices.

When one prime mover drives two pieces of equipment, one of which is either a standard Falk geared drive or a customer standard geared drive, the division of power between each machine is the responsibility of the customer. The power supplied to the geared drive must be equal to or less than the power for which the drive was selected using the appropriate service factor for the application. The customer must also assume the responsibility of isolating the geared drive from any vibratory or transient load induced by the driven equipment.

Install and operate Falk products in conformance with applicable local and national safety codes and per Falk owner's manual which is available upon request. Suitable guards for rotating

Copyright 1979, 2006. Rexnord Industries, LLC.
All Rights Reserved. Litho in USA.

FALK, EQUI-POISED, QUADRIVE, RENEW, STEELFLEX, TA TAPER, TORUS, and "a good name in industry" are registered trademarks.

The contents of this selection guide are subject to change without notice or obligation. Information contained herein should be confirmed before placing orders.

members may be purchased from Falk as optional accessories. Consult your local Falk Representative for complete details.

People Conveying Equipment — Selection of Falk products for applications whose primary purpose is the transportation of people is not approved. This includes such applications as freight or passenger elevators, escalators, man lifts, work lift platforms and ski tows and ski lifts.

If the primary purpose of the application is material conveyance and occasionally people are transported, the Falk warranty may remain in effect provided the design load conditions are not exceeded and certification to the appropriate safety codes and load conditions has been obtained by the system designer or end user from the appropriate enforcement authorities.

Gear Drive Ratings

Shaft Mounted, Flange Mounted and Screw Conveyor Drives are rated to a specific application by the use of Load Classifications. Each application has its own conditions and operating requirements. These have been analyzed and catalogued into three load classifications . . . uniform, moderate shock and heavy shock. Load classifications, based on field experience, have been assigned to these applications for service of 3 to 10 hours per day, and for service over 10 hours per day, and also for the type of prime mover. Values for most applications are listed on Page 9. Refer unlisted applications to Falk.

Load Classifications are based on the assumption that the system is free of dynamic vibrations, as explained in the warranty section. Refer applications subject to repetitive shocks and applications where exceedingly high energy load must be absorbed, as when stalling, to Falk for special consideration.

Operating Temperature — Gear drives can encounter sump oil temperatures up to 200°F (93°C). Higher temperatures are possible in localized areas. Since the drive will feel hot to the human hand at temperatures over 120°F (49°C), a portable pyrometer should be used to measure temperatures. Some drives, as indicated in the selection tables, are furnished with fans to ensure satisfactory operating temperatures.

Conditions Affecting Gear Drive Selection and Application — The following conditions may affect the drive selection procedure, drive size and auxiliary equipment being furnished. Refer to Page 6 for more information.

- Excessive Overloads
- Reversing Service
- Brake Equipped Applications
- Oversized Prime Movers
- Multi-Speed or Variable Speed Applications
- Excessive Ambient Temperatures
- Excessive Overhung Loads or Thrust Loads
- Non-Standard Mounting Positions
- Product Modification
- Backstops

Stored & Inactive Drives — Each gear drive is spin-tested with a rust preventive oil that will protect parts against rust for a period of four months in an outdoor shelter or twelve months in dry building after shipment from Falk.

Periodically inspect stored or inactive drives and spray or add rust inhibitor every six months or more often, if necessary. Indoor dry storage is recommended.

Drives ordered for extended storage can be treated at Falk with a special preservative and sealed to rustproof parts for periods longer than those cited above, if specified on the order.

Refer to appropriate service manual for extended storage of gear drives which have been in service.

Conditions Affecting Selections

Non-Standard Application Procedures

The following conditions may affect the drive selection procedure, drive size and auxiliary equipment being furnished.

Excessive Overloads — The maximum momentary or starting load must not exceed 200% of rated load (100% overload). Gear drive selections allow the following minimum momentary overloads for electric motor applications:

Class I Selections: 100% overload, or 200% of nominal motor rating.

Class II Selections: 180% overload, or 280% of nominal motor rating.

Class III Selections: 300% overload, or 400% of nominal motor rating.

If the maximum starting or momentary load exceeds the above conditions, Refer to Factory.

Reversing Service — Applications involving either more than 20 reversals per 10 hour period, or less than 20 reversals per 10 hour period with peak torques greater than 200% of normal load must be referred to Falk.

Brake Equipped Applications — When a gear drive is equipped with a “working” brake that is used to decelerate the motion of the system and the brake is located between the prime mover and the gear drive, select the drive based on the brake rating or the highest equivalent power rating, whichever is greater. If the brake is used for holding only and is applied after the motion of the system has come to rest, the brake rating must be less than 200% of the catalog rating of the gear drive selected for the application. If the brake rating is greater than 200% of the gear drive catalog rating, refer the application to Falk. Also Refer to Factory all applications in which the brake is located on the output shaft of the gear drive.

Oversize Prime Movers — Published Service Factors do not cover applications that require oversize prime movers for high energy or peak loads. Refer such applications to Falk for selection of suitable drives.

Speed Variation — When selecting gear drives for multi-speed or variable speed applications, determine the speed which develops the greatest torque and select the gear drives on this basis. If the speed is not listed in the selection table, use the next lower output speed.

Refer all variable and multi-speed applications to Falk. They may require special consideration to provide adequate lubrication at the slowest speed, but without excessive heating or churning at the highest speed. It is essential that all orders indicate minimum and maximum speeds, as well as the speed duration cycles.

Effects of Solar Energy — If a drive operates in the sun at ambient temperatures over 100°F (38°C), then special measures must be taken to protect the drive from solar energy. This protection can consist of a canopy over the drive or reflective paint on the drive. If neither is possible, additional cooling may be required to prevent the sump temperature from exceeding the allowable maximum of 200°F (93°C).

Overhung Loads and Thrust Loads — The overhung load and thrust ratings published in this selection guide are based on a service factor of unity and a combination of the most unfavorable conditions of rotation, speed, direction of applied load and drive loading. If the calculated load exceeds the published value, or if an overhung load and thrust load are applied simultaneously to a shaft, refer complete application details to Falk. For more information refer to tables and guidelines on Pages 14 and 15.

Product Modifications — Falk can supply special product modifications to suit your application needs. Contact your local Falk representative for housing modifications, special ratios, special shafts, special mounting conditions, accessory modifications and other special application requirements.

Mounting Positions — All drives must be mounted within the limits specified on the dimension pages unless specifically ordered otherwise. Unless Factory approved, other mounting positions may lower the oil to a level that will starve gears and bearings; overfilling a drive with oil may cause leakage through the air vent, foaming and churning and consequently, overheating. Either condition can result in damage to gears and bearings.

Backstops — Backstops provide positive prevention of reverse rotation or backrun without backlash on conveyors, elevator head shafts and similar applications. Designed as standard accessories, backstops can be furnished on horizontal drives. Do not use backstops on vertical drives.

DO NOT use the backstop as a substitute for a brake.

These backstops are designed to prevent reverse rotation five times or less in eight hours, with one minute or more in the overrunning direction between backstopping load applications. If backstopping operations are more frequent, or the time between operations is less than one minute, the backstop is classified as a working or indexing device and the application must be referred to Falk for engineering review.

When ordering a drive equipped with a backstop, specify whether the Falk hollow shaft is to rotate clockwise or counterclockwise when facing the input side of the gear drive.

How to Select

1. Information required.
 - Driven machine
 - Motor horsepower/rpm/frame size
 - Hours/day operation
 - Driven shaft diameter/rpm
 - Mounting requirements/space limits

If you have an unusual application involving any of the following conditions, refer to Page 6.

- Excessive overloads
 - Reversing service
 - Brake equipped applications
 - Oversized prime movers
 - Multi-speed or variable speed applications
 - Excessive ambient temperatures
 - Excessive overhung loads or thrust loads
 - Product modifications
 - Non-standard mounting positions
2. Drive selection.

Determine load classification based on the application from Table 1, Page 9. Refer to Class I, II or III Selection Tables on Pages 10 thru 12. Select basic gear drive size and ratio opposite desired horsepower and output speed (Note the minimum high speed shaft sheave pitch diameter). Determine drive Type JR (Shaft Mounted Drive), JF (Flange Mounted Drive) or JSC (Screw Conveyor Drive). Also check the overhung load and thrust load. Thermal capacities in selection tables are based on 80°F(27°C) ambient. If ambient temperature exceeds this value, Refer to Factory.

The selection tables show the most economical drive ratio for a given speed. If a different drive ratio is required to meet application or delivery requirements, refer to the Ratio Substitution Table on Page 13.
 3. Check dimensions.

Refer to drive size dimension pages and check TA taper bushing bore, mounting position, clearances, and motor mount & motor frame size details.
 4. Sheave ratios.

Nominal sheave ratios are given in Table 12, on Page 42. Select final V-belt to suit the motor mount center distance and compare the driven sheave pitch diameter to the minimum determined in the selection table.

Example

1. Application Details
Uniformly loaded inclined belt conveyor.
20 Horsepower, 1750 rpm motor, 256 T frame.
10 Hours/day operation.
2¹¹/₁₆" Diameter head shaft at 44 rpm.
Shaft mounted drive/horizontal.
2. The Load Classification from Table 1, on Page 9, is Class I. From the Class I selection, Table 2, on Page 10, opposite 20 hp and output range of 60-37 rpm, the drive size is 5215J_25A with a minimum H.S. sheave pitch diameter of 6.0". Drive type is a "JR" shaft mounted drive.
3. Refer to Pages 24 and 25 to check drive dimension data. A hollow shaft Bushing No. BU5215J-2.688, Part No. 0769143 is required to fit the drive to the 2¹¹/₁₆" diameter headshaft. A 6-o'clock mounting position is required. The motor mount center distance range available is 24.8-37.2", with a 256T frame motor.
4. From Table 12, on Page 42, the nominal sheave ratio is 1.59 for a 25:1 ratio drive with a 1750 rpm motor, at 44 rpm output. Select the V-belt drive to suit the available center distance range (short, medium or long). Be sure to allow for belt take up. Also, verify that the driven sheave pitch diameter is larger than the minimum specified.

Order:

Basic Drive 5215JR25A PN 0794385
Bushings BU5215J-2.688 PN 0769143
Torque Arm TA52157J PN 0785267
Motor Mount MM5215J-2 PN 0786261
Backstop BS5215J05/09/14/25 PN 0785610
Clockwise rotation
V-Belt Guard

How to Order

The following information is required to quote or ship to your requirements.

Sizes 5107 thru 5315

JR Shaft Mounted Drive

1. Basic Drive/Ratio (PN)
2. Bushing Size/Bore (PN)
3. Torque Arm (PN)

JF Flange Mounted Drive

1. Basic Drive/Ratio (PN)
- Bushing Size/Bore (PN)— Optional
(See Manual 377-142)

JSC Screw Conveyor Drive

1. Basic Drive/Ratio (PN)
 2. Seal Housing (PN)
- Seal Options (PN)
3. Drive Shaft Dia. (PN)
- Thrust Plate Kit Included

Sizes 5407 thru 5608

JR Shaft Mounted Drive

1. Drive/Ratio (PN)
- Torque Arm Included
2. Bushing Size/Bore (PN)

JF Flange Mounted Drive

1. Drive/Ratio (PN)
- Flange Included
- Bushing Size/Bore (PN)— Optional
(See Manual 377-144)

JSC Screw Conveyor Drive (5407 only)

1. Drive/Ratio (PN)
- Seal Housing Included
2. Drive Shaft Dia. (PN)
- Thrust Plate Kit Included

Accessories

Motor Mount—Description/Motor Frame Size (PN)

Backstop—Description/L.S. Rotation Viewing Input Side (PN) (Not available on vertical drives.)

Shaft Cooling Fan—Specify on Order/Factory Installed (5215-5608J only)

Electric Fan—Description (PN)/Specify Fan Mounting Position (5407-5608J) If Factory Installed

Vertical Breather—Description/H.S. Shaft Up or Down (PN)

Trough End—Description (PN)

Thrust Plate Kit—Description (PN)

TA Removal Tool—Description (PN)

V-Belt Guard—Description (PN)

TCB (Taper Conversion Bushing)—Description (PN)

Contact Falk for special design options.

DRIVE NOMENCLATURE

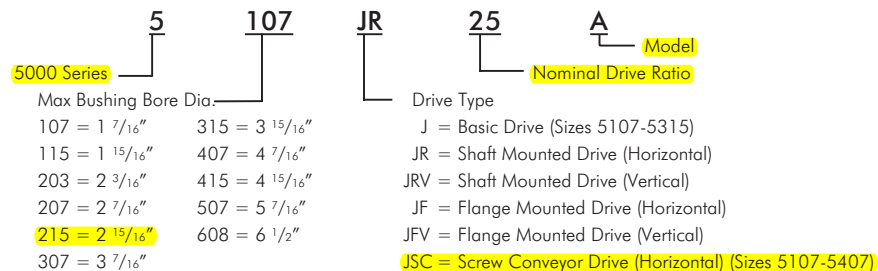

Load Classifications * . . . Electric Motor Driven Applications

Recommendations are minimum and normal conditions are assumed.

TABLE 1

APPLICATION	Service		APPLICATION	Service		APPLICATION	Service		APPLICATION	Service	
	3 to 10 Hour	Over 10 Hour		3 to 10 Hour	Over 10 Hour		3 to 10 Hour	Over 10 Hour		3 to 10 Hour	Over 10 Hour
AGITATORS			Belt	I	II	LINE SHAFTS			PUMPS		
Paper Mill (Mixers)	II	II	Flight	II	II	Uniform Load	I	II	Proportioning	Refer to Factory	
Pure Liquids	I	II	Oven	I	II	Heavy Load	II	II	Reciprocating, open		
Semi-Liquids, Variable			Live Roll (Package)	I	II				Discharge	I	II
Density	II	II	Screw	I	II	LIVE ROLL CONVEYORS			Double Acting		
			Table—See Metal Mills	III	III	Uniformly Loaded, Package	I	II	Multi-Cylinder	II	III
APRON CONVEYORS			CONVEYORS—HEAVY DUTY			Heavy Duty	Refer to Factory		Single Cylinder	Refer to Factory	
Uniformly Loaded	I	II	—NOT UNIFORMLY FED †						Rotary (Gear Type)		
Heavy Duty	II	III	Apron	II	III	MACHINE TOOLS			Constant Density	I	II
ASSEMBLY CONVEYORS			Assembly	II	II	Auxiliary Drives	I	II	Variable Density	II	II
Uniformly Loaded	I	II	Belt	II	II	Main Drives Uniform Load	II	II	RECIPROCATING		
Heavy Duty	II	II	Bucket or Pan	II	II	Main Drives Heavy Load	III	III	Conveyors	III	III
BELT CONVEYORS			Flight	II	II				RUBBER INDUSTRY		
Uniformly Loaded	I	II	Live Roll	Refer to Factory		METAL MILLS			Tire Building Machines	II	II
Heavy Duty	II	II	Oven	II	II	Table Conveyors,			Tire & Tube Press Openers	I	I
BREWING & DISTILLING			Reciprocating	III	III	Non Reversing	II	III			
Bottling Machinery	I	II	Screw	II	I	Reversing	Refer to Factory		SCREENS		
Brew Kettles, Continuous	II	II	Table—See Metal Mills	III	III	Wire Drawing & Flattening			Air Washing	I	II
Can Filling Machines	I	II	CRANES & HOISTS †			Machines	II	III	Rotary, Stone or Gravel	II	II
Cookers, Continuous	II	II	Bridge and Trolley Drive	II	II	MILLS			Traveling Water Intake	I	II
Mash Tubs, Continuous	III	III	CUTTER HEAD DRIVES	Refer to Factory		(See Metal Mills)			Shaker	II	III
Scale Hoppers, Frequent			DISTILLING — See Brewing	III	III	Pebble	II	III	SCREW CONVEYORS		
Starts	II	II	DRYERS & COOLERS,			MIXERS (See Agitators)			Uniformly Loaded	I	II
			ROTARY			Concrete, Continuous	II	III	Heavy Duty	II	II
BUCKET			ELEVATORS			Concrete, Intermittent	II	III	Ski Tows & Lifts †	Not Approved	
Conveyors Heavy Duty	II	II	Bucket—Uniform Load	I	II	Constant Density	I	II	SKIP HOISTS †	II	III
Elevators, Uniform Load	I	II	Bucket—Heavy Load	II	III	Variable Density	II	II			
Elevators, Heavy Duty	II	III	Escalators†	Not Approved		Liquid	I	II	STOKERS	III	III
CAN FILLING MACHINES			Freight†	Not Approved		Paper Mill (Agitators)	II	II	TEXTILE INDUSTRY		
			Man lifts, Passenger†	Not Approved		Semi-Liquid	II	II	Batchers	II	II
CAR						OVEN CONVEYORS			Calenders	II	II
Dumpers	III	III	FLIGHT CONVEYORS			Uniformly Loaded	I	II	Card Machines	III	III
Pullers	Refer to Factory		Uniformly Loaded	II	II	Heavy Duty	II	II	Dry Cans	II	II
CLARIFIERS			Heavy Duty	II	II	PAN CONVEYORS			Dyeing Machinery	II	II
						Heavy Duty	II	II	Looms	Refer to Factory	
CLASSIFIERS			FOOD INDUSTRY			PAPER MILLS			Mangles, Nappers & Soapers	II	II
			Beet Slicers	II	II	Agitators (Mixers)	II	II	Spinners	II	III
CLAY WORKING			Can Filling Machines	I	II	Bleachers	I	II	Tenter Frames	II	II
MACHINERY			Cereal Cookers	I	II	Calenders	III	III	TUMBLING BARRELS	III	III
Brick Presses	III	III	Dough Mixers	II	II	Cylinders	II	II	WINDLASS	II	III
Briquette Machines	III	III	Meat Grinders	II	II	Felt Stretchers	II	II			
Extruders & Mixers	II	III	LAUNDRY			Winders	II	II			
CONVEYORS—UNIFORMLY			Washers, reversing	Refer to Factory		PEBBLE MILLS					
LOADED OR FED †			Tumblers	II	III						
Apron and Assembly	I	II									

* **LOAD CLASSIFICATIONS FOR ENGINE-DRIVEN APPLICATIONS — Multi-Cylinder Engines:** Use the next higher Service Class than the one given in Table 1 for the same application when motor driven. (Example: A motor-driven uniformly loaded belt conveyor for 10 hour service is Class I; the same conveyor driven by a multi-cylinder engine would be Class II). For applications which require Class III when motor driven, Refer to Factory for recommendations on engine drives. **Single Cylinder Engines:** Refer to Factory.

† Selection of Falk products for applications whose primary purpose is the transportation of people is not approved. This includes such applications as freight or passenger elevators, escalators, man lifts, fork lift platforms and ski tows and ski lifts. If the primary purpose of the application is material conveyance and occasionally people are transported, the Falk warranty may remain in effect provided the design load conditions are not exceeded and certification to the appropriate safety codes and load conditions has been obtained by the system designer or end user from the appropriate enforcement authorities.

Class I

Selections for ★ Shaft (JR) and Flange (JF) Mounted Drives — Sizes 5107 thru 5608
Screw Conveyor (JSC) Drives — Sizes 5107 thru 5407

TABLE 2

HP	Output rpm	Drive Size	Min H.S.S. Sheave Pitch Dia †	HP	Output rpm	Drive Size	Min H.S.S. Sheave Pitch Dia †	HP	Output rpm	Drive Size	Min H.S.S. Sheave Pitch Dia †	HP	Output rpm	Drive Size	Min H.S.S. Sheave Pitch Dia †						
1/4	350-191	5107J_05	1.7	7-1/2	70-58	5115J_25	2.6	30	350-251	5207J_05	5.5	75 Cont	70-67	5315J_25*	7.0						
	190-126	5107J_09	1.7		57-37	5203J_25	4.0		250-201	5207J_05	11.3		70-45	5407J_25*	7.0						
	125-71	5107J_14	1.7		36-23	5207J_25	5.0		200-191	5215J_05	6.0		44-34	5415J_25*	8.0						
	70-5	5107J_25	1.8		22-14	5215J_25	6.0		190-151	5207J_09	5.0		33-22	5507J_25	8.0						
1/3	350-191	5107J_05	1.7		10	13-9	5307J_25		7.0	40	150-126	5207J_09	7.2	100	21-15	5608J_25	9.5				
	190-126	5107J_09	1.7			8-7	5315J_25		7.0		125-94	5207J_14	7.9		350-321	5307J_05+	11.7				
	125-71	5107J_14	1.7			6-5	5407J_25		7.0		93-71	5215J_14	6.0		320-286	5307J_05+	15.0				
	70-5	5107J_25	1.9			15	350-219		5107J_05		3.7	70-55	5215J_25		6.0	285-221	5315J_05	8.2			
1/2	350-191	5107J_05	1.7						218-191		5115J_05	2.6	54-34		5307J_25	7.0	220-191	5315J_05	10.6		
	190-126	5107J_09	1.7						190-146		5107J_09	2.2	33-27		5315J_25	7.0	190-126	5315J_09*	11.5		
	125-71	5107J_14	1.7						145-126		5115J_09	2.0	32-18		5407J_25	7.0	190-126	5407J_05	7.0		
	70-7	5107J_25	2.1						125-79		5115J_14	2.0	17-14		5415J_25	8.0	125-115	5307J_14*	7.9		
3/4	350-191	5107J_05	1.7	78-71				5203J_14	4.0		13-9	5507J_25	8.0		125-111	5407J_05	7.8	125	114-89	5315J_14*	14.0
	190-126	5107J_09	1.7	70-49				5203J_25	4.0		11-9	5315J_25	7.0		88-71	5407J_14*	7.0				
	125-71	5107J_14	1.7	48-31				5207J_25	5.0		8-6	5407J_25	7.0		88-71	5415J_14+	8.0				
	70-12	5107J_25	2.1	30-19				5215J_25	6.0		5	5415J_25	8.0		70-60	5407J_25*	7.0				
1	350-191	5107J_05	1.7	18-12	5307J_25			7.0	20	125-73	5215J_14+	6.6	59-46	5415J_25*	8.0	150	45-29		5507J_25+	8.0	
	190-126	5107J_09	1.7	11-9	5315J_25			7.0		72-71	5307J_14	7.0	28-20	5608J_25	9.5						
	125-71	5107J_14	1.7	8-6	5407J_25			7.0		70-45	5307J_25	7.0	350-301	5315J_05+	10.0						
	70-14	5107J_25	2.1	5	5415J_25	8.0	44-36	5315J_25		7.0	300-241	5315J_05+	15.0								
1-1/2	350-191	5107J_05	1.7	350-191	5115J_05	5.3	50	350-261		5215J_05	6.0	240-221	5315J_05+	19.0	200		350-311		5315J_05*	13.1	
	190-126	5107J_09	1.7	190-126	5115J_09	2.6		260-231		5215J_05	7.5	220-191	5407J_05+	10.0							
	125-71	5107J_14	1.7	125-118	5115J_14	2.0		230-201		5215J_05	13.4	190-161	5407J_05+	13.4							
	70-14	5107J_25	2.1	117-73	5203J_14	4.0		200-191		5307J_05	7.0	160-148	5315J_09*	16.6							
2	350-191	5107J_05	1.7	72-71	5207J_14	5.0		60		190-126	5215J_05	6.0	190-126	5407J_05			10.1	250	350-311	5407J_05+	7.4
	190-126	5107J_09	1.7	70-46	5207J_25	5.0				190-126	5215J_09+	6.0	125-111	5407J_05			12.2				
	125-71	5107J_14	1.7	45-28	5215J_25	6.0				125-91	5215J_14+	8.0	125-80	5407J_14*			7.0				
	70-22	5107J_25	2.1	27-17	5307J_25	7.0				90-79	5215J_14+	8.0	79-71	5415J_14*			8.0				
3	350-191	5107J_05	1.7	16-14	5315J_25	7.0			75	125-91	5307J_14+	7.0	79-71	5407J_14+		8.0	250		350-311	5407J_05+	8.0
	190-126	5107J_09	1.7	13-9	5407J_25	7.0				78-71	5307J_14	7.0	70-57	5415J_25*		8.0					
	125-71	5107J_14	1.7	8-7	5415J_25	8.0				70-56	5307J_25+	7.0	70-57	5507J_25*		8.0					
	70-22	5107J_25	2.1	6-5	5507J_25	8.0				70-56	5315J_25+	7.0	56-37	5507J_25*		8.0					
5	350-191	5107J_05	1.7	350-275	5115J_05	5.7	25			70-56	5407J_25+	7.0	56-25	5608J_25+	9.9	250			350-311	5315J_05*	13.1
	190-126	5107J_09	1.7	230-274	5115J_05	8.5				55-45	5315J_25+	7.0	350-311	5407J_05+	7.4						
	125-71	5107J_14	1.7	225-229	5203J_05	10.8				44-30	5407J_25+	7.0	350-311	5407J_05+	7.4						
	70-28	5107J_25	2.1	191-224	5207J_05	5.0				29-23	5415J_25	8.0	310-291	5315J_05*	15.8						
7-1/2	350-191	5107J_05	1.7	190-168	5115J_09	3.0		25		22-15	5507J_25	8.0	310-276	5407J_05+	8.3			250	350-311	5407J_05+	7.4
	190-126	5107J_09	1.7	167-126	5203J_09	7.3				14-10	5608J_25	9.5	275-201	5407J_05+	11.4						
	125-71	5107J_14	1.7	125-103	5203J_14	4.5				250	350-301	5215J_05	7.4	200-171	5407J_05+				13.4		
	70-41	5107J_25	2.1	102-71	5207J_14	5.0					300-261	5215J_05	13.4	170-141	5407J_05+				16.2		
40-23	5115J_25	2.6	70-61	5207J_25	5.0	260-191			5307J_05		7.0	140-126	5415J_05+	18.0							
22-15	5203J_25	4.0	60-37	5215J_25	6.0	190-178			5307J_05		7.3	125-71	5415J_14*	8.0							
14-10	5207J_25	5.0	36-23	5307J_25	7.0	177-156			5307J_09+		7.0	125-111	5415J_05+	20.3							
9-6	5215J_25	6.0	22-18	5315J_25	7.0	155-126			5307J_09+		9.1	70-44	5507J_25*	8.0							
5	5307J_25	7.0	17-12	5407J_25	7.0	125-71	5307J_14+		7.4		70-30	5608J_25+	9.9								
7-1/2	350-191	5107J_05	2.0	11-9	5415J_25	8.0	250		70-53		5315J_25+	7.0	250	350-301	5407J_05*	8.0					
	190-126	5107J_09	1.7	8-6	5507J_25	8.0			52-36		5407J_25+	7.0		300-251	5407J_05*	9.8					
	125-71	5107J_14	1.7	5	5608J_25	9.5			35-28		5415J_25+	8.0		268-251	5415J_05+	12.0					
	70-39	5115J_25	2.6	350-331	5203J_05	7.7		27-18	5507J_25		8.0	250-201		5407J_05*	13.9						
7-1/2	350-191	5107J_05	2.8	330-311	5203J_05	10.5		25	17-12		5608J_25	9.5		250-162	5415J_05+	18.5	250	350-301	5407J_05*	8.0	
	190-126	5107J_09	1.7	310-191	5207J_05	5.6			75	350-281	5307J_05	6.0		161-151	5415J_05*	14.0					
	125-71	5107J_14	1.7	190-160	5203J_09	9.3				280-216	5307J_05	9.1		150-131	5415J_05*	17.9					
	70-39	5115J_25	2.6	159-126	5207J_09	5.0				215-191	5307J_05	12.0		130-111	5415J_05*	25.6					
38-25	5203J_25	4.0	125-101	5207J_14	5.0	190-151				5307J_09*	9.0	110-71		5507J_14*	8.0						
24-16	5207J_25	5.0	100-76	5207J_14	6.9	190-151				5307J_09*	9.0	70-36		5608J_25*	9.5						
15-10	5215J_25	6.0	75-71	5215J_14	6.0	150-126				5315J_05	10.7	250		88-60	5608J_14*	9.5					
9-6	5307J_25	7.0	70-46	5215J_25	6.0	125-84				5307J_14*	14.0			59-51	5608J_25*	11.1					
5	5315J_25	7.0	45-28	5307J_25	7.0	125-111	5315J_05			14.6	50-45		5608J_25*	19.0							
350-191	5107J_05	2.8	27-22	5315J_25	7.0	83-71	5315J_14*			7.4											
190-126	5107J_09	1.7	21-15	5407J_25	7.0	83-71	5407J_14+			7.0											
125-112	5107J_14	1.7	14-12	5415J_25	8.0																
111-71	5115J_14	2.0	11-8	5507J_25	8.0																
				7-5	5608J_25	9.5															

★ † ‡ ● (See footnotes on Page 11.)

Class II

Selections for ★ Shaft (JR) and Flange (JF) Mounted Drives — Sizes 5107 thru 5608
Screw Conveyor (JSC) Drives — Sizes 5107 thru 5407

TABLE 3

HP	Output rpm	Drive Size	Min H.S.S. Sheave Pitch Dia †	HP	Output rpm	Drive Size	Min H.S.S. Sheave Pitch Dia †	HP	Output rpm	Drive Size	Min H.S.S. Sheave Pitch Dia †	HP	Output rpm	Drive Size	Min H.S.S. Sheave Pitch Dia †
1/4	350-191	5107J_05	1.7	7-1/2 Cont	70-44	5302J_25	4.0	30	350-301	5207J_05	6.7	100	350-296	5315J_05†	9.6
	190-126	5107J_09	1.7		43-28	5207J_25	5.0		300-260	5207J_05	11.9		295-251	5315J_05	10.6
	125-71	5107J_14	1.7		27-17	5215J_25	6.0		259-191	5215J_05	6.0		250-221	5315J_05	14.5
	70-5	5107J_25	1.7		16-11	5307J_25	7.0		190-150	5207J_09	9.2		220-166	5315J_09*	11.3
1/3	350-191	5107J_05	1.7	10	10-8	5315J_25	7.0	40	149-126	5215J_09	6.0	125	165-141	5315J_09*	16.5
	190-126	5107J_09	1.7		7-6	5407J_25	7.0		125-71	5215J_14	6.0		220-126	5407J_05	9.4
	125-71	5107J_14	1.7		5	5415J_25	8.0		70-66	5215J_25	6.0		125-117	5315J_14*	13.9
	70-6	5107J_25	1.9		350-297	5107J_05	3.2		65-41	5307J_25	7.0		116-77	5407J_14*	7.0
1/2	350-191	5107J_05	1.7	15	296-191	5115J_05	3.5	50	40-32	5315J_25	7.0	200	76-71	5415J_14	9.5
	190-126	5107J_09	1.7		190-177	5107J_09	2.4		31-22	5407J_25	7.0		70-55	5415J_25*	8.0
	125-71	5107J_14	1.7		176-126	5115J_09	2.0		21-17	5415J_25	8.0		54-35	5507J_25†	8.0
	70-9	5107J_25	1.9		125-95	5115J_14	2.0		16-11	5507J_25	8.0		34-24	5608J_25	9.5
3/4	350-191	5107J_05	1.7	20	94-71	5203J_14	4.0	60	10-7	5608J_25	9.5	75	350-311	5407J_05†	7.4
	190-126	5107J_09	1.7		70-63	5203J_25	4.0		350-225	5215J_05	7.0		310-181	5407J_05†	12.7
	125-71	5107J_14	1.7		62-37	5207J_25	5.0		224-191	5307J_05	7.0		180-156	5407J_05	10.9
	70-9	5107J_25	1.9		36-22	5215J_25	6.0		270-191	5307J_05	7.0		155-136	5407J_05	13.6
1	350-191	5107J_05	1.7	25	21-14	5307J_25	7.0	75	190-126	5215J_09	6.0	250	135-126	5407J_05	15.7
	190-126	5107J_09	1.7		13-11	5315J_25	7.0		125-88	5215J_14†	7.7		125-96	5407J_14*	7.0
	125-71	5107J_14	1.7		10-8	5407J_25	7.0		87-71	5307J_14	7.0		95-71	5415J_14*	8.0
	70-9	5107J_25	1.9		7-6	5415J_25	8.0		70-54	5307J_25	7.0		70-67	5415J_25*	8.0
1-1/2	350-191	5107J_05	1.7	30	350-301	5115J_05	4.1	80	53-43	5315J_25	7.0	300	66-44	5507J_25†	8.0
	190-126	5107J_09	1.7		300-251	5115J_05	5.3		42-29	5407J_25	7.0		43-30	5608J_25†	9.9
	125-71	5107J_14	1.7		251-210	5115J_05	7.1		28-22	5415J_25	8.0		350-301	5407J_05†	9.2
	70-17	5107J_25	2.1		209-191	5207J_05	5.0		21-14	5507J_25	8.0		300-221	5407J_05†	12.5
2	350-191	5107J_05	1.7	40	190-153	5115J_09	2.8	100	13-10	5608J_25	9.5	150	220-176	5407J_05†	17.4
	190-126	5107J_09	1.7		152-126	5203J_09	5.1		350-300	5215J_05	8.0		175-156	5415J_05†	17.4
	125-71	5107J_14	1.7		125-90	5203J_14	4.5		300-191	5307J_05	7.0		155-146	5415J_05†	18.6
	70-10	5107J_25	2.0		89-71	5207J_14	5.0		190-126	5215J_09*	8.7		145-136	5415J_05†	20.0
3	350-191	5107J_05	1.7	50	70-55	5207J_25	5.0	150	125-110	5215J_14†	9.6	200	135-126	5415J_05†	21.6
	190-126	5107J_09	1.7		54-33	5215J_25	6.0		109-88	5307J_14†	9.7		125-84	5415J_14*	8.0
	125-71	5107J_14	1.7		32-21	5307J_25	7.0		87-71	5307J_14	7.0		83-71	5507J_14*	8.0
	70-26	5107J_25	2.0		20-16	5315J_25	7.0		70-68	5307J_25†	7.0		70-53	5507J_25*	8.0
4	350-191	5107J_05	1.7	60	15-11	5407J_25	7.0	200	67-54	5315J_25†	7.0	250	52-36	5608J_25*	9.9
	190-126	5107J_09	1.7		10-9	5415J_25	8.0		53-36	5407J_25†	7.0		350-271	5407J_05*	13.2
	125-71	5107J_14	1.7		8-6	5507J_25	8.0		35-28	5415J_25	8.0		270-231	5407J_05*	17.8
	70-13	5107J_25	2.0		5	5608J_25	9.5		27-18	5507J_25	8.0		230-176	5415J_05†	20.7
5	350-191	5107J_05	1.7	75	350-300	5115J_05	8.8	200	17-12	5608J_25	9.5	300	175-166	5415J_05†	23.2
	190-126	5107J_09	1.7		299-259	5203J_05	12.1		350-301	5307J_05	7.0		165-156	5415J_05*	21.8
	125-71	5107J_14	1.7		258-191	5207J_05	5.0		300-191	5307J_05	10.6		155-71	5507J_14*	8.1
	70-34	5107J_25	2.0		190-146	5203J_09	11.2		190-126	5315J_09*	7.0		70-48	5608J_25*	9.5
7-1/2	350-191	5107J_05	1.7	80	145-126	5207J_09	5.0	250	175-155	5307J_09*	10.1	300	350-271	5407J_05*	13.2
	190-126	5107J_09	1.7		125-74	5207J_14	6.5		155-126	5307J_09*	15.7		270-231	5407J_05*	17.8
	125-71	5107J_14	1.7		73-71	5215J_14	6.0		125-81	5307J_14†	8.6		230-176	5415J_05†	20.7
	70-51	5107J_25	2.1		70-44	5215J_25	6.0		80-71	5315J_14†	10.0		175-166	5415J_05†	23.2
10	350-191	5107J_05	1.7	100	43-27	5307J_25	7.0	250	70-65	5315J_25†	7.0	300	165-156	5415J_05*	21.8
	190-126	5107J_09	1.7		26-22	5315J_25	7.0		64-43	5407J_25†	7.0		155-71	5507J_14*	8.1
	125-71	5107J_14	1.7		21-15	5407J_25	7.0		42-33	5415J_25†	8.0		70-48	5608J_25*	9.5
	70-51	5107J_25	2.1		14-11	5415J_25	8.0		32-21	5507J_25	9.6				
15	350-191	5107J_05	1.7	150	10-7	5507J_25	8.0	200	20-15	5608J_25	9.5	250	350-301	5307J_05	8.1
	190-126	5107J_09	1.7		350-321	5207J_05	5.0		300-251	5307J_05	11.9		300-251	5307J_05	16.8
	125-71	5107J_14	1.7		229-205	5207J_05	10.5		250-225	5307J_05	8.2		224-191	5315J_05	8.2
	70-51	5107J_25	2.1		205-191	5215J_05	6.0		190-166	5307J_09*	13.8		190-166	5307J_09*	13.8
20	350-191	5107J_05	1.7	200	190-126	5207J_09	7.3	250	165-126	5315J_09*	8.9	300	125-102	5307J_14*	7.7
	190-126	5107J_09	1.7		125-96	5207J_14	7.6		101-81	5315J_14*	12.3		80-71	5407J_14†	7.0
	125-71	5107J_14	1.7		95-71	5215J_14	6.0		70-55	5407J_25†	7.0		70-55	5407J_25†	7.0
	70-47	5115J_25	2.6		54-34	5307J_25	7.0		33-27	5315J_25	7.0		54-41	5415J_25†	7.0
30	350-191	5107J_05	1.7	250	26-18	5407J_25	7.0	300	40-27	5507J_25	8.0	350	26-18	5608J_25	9.5
	190-126	5107J_09	1.7		17-14	5415J_25	8.0		13-9	5507J_25	8.0				
	125-71	5107J_14	1.7		13-9	5507J_25	8.0		8-6	5608J_25	9.5				
	70-47	5115J_25	2.6		8-6	5608J_25	9.5								
40	350-191	5107J_05	1.7	300	350-301	5115J_05	4.1	350	350-301	5307J_05	8.1	400	350-223	5107J_05	3.1
	190-126	5107J_09	1.7		300-251	5115J_05	5.3		300-251	5307J_05	11.9		222-191	5115J_05	2.2
	125-71	5107J_14	1.7		251-210	5115J_05	7.1		250-225	5307J_05	16.8		190-132	5107J_09	2.2
	70-17	5107J_25	2.1		209-191	5207J_05	5.0		224-191	5315J_05	8.2		131-126	5203J_09	4.0
50	350-191	5107J_05	1.7	400	190-153	5115J_09	2.8	450	190-166	5307J_09*	13.8	500	125-71	5107J_14	1.7
	190-126	5107J_09	1.7		152-126	5203J_09	5.1		165-126	5315J_09*	8.9		89-71	5115J_14	2.0
	125-71	5107J_14	1.7		125-90	5203J_14	4.5		101-81	5315J_14*	12.3		70-47	5115J_25	2.6
	70-10	5107J_25	2.0		89-71	5207J_14	5.0		80-71	5407J_14†	7.0		46-30	5203J_25	4.0
75	350-191	5107J_05	1.7	500	70-55	5207J_25	5.0	550	70-55	5315J_25	7.0	600	29-19	5207J_25	5.0
	190-126	5107J_09	1.7		54-34	5307J_25	7.0		70-55	5407J_25†	7.0		18-11	5215J_25	6.0
	125-71	5107J_14	1.7		33-27	5315J_25	7.0		54-41	5415J_25†	7.0		10-7	5307J_25	7.0
	70-13	5107J_25	2.0		26-18	5407J_25	7.0		40-27	5507J_25	8.0		5	5215J_25	6.0
100	350-191	5107J_05	1.7	600	17-14	5415J_25	8.0	700	26-18	5608J_25	9.5	800	350-271	5407J_05*	13.2
	190-126	5107J_09	1.7		13-9	5507J_25	8.0		17-12	5608J_25	9.5		270-231	5407J_05*	17.8
	125-71	5107J_14	1.7		8-6	5608J_25	9.5						230-176	5415J_05†	20.7
	70-13	5107J_25	2.0										175-166	5415J_05†	23.2
150	350-191	5107J_05	1.7												

Class III

Selections for ★ Shaft (JR) and Flange (JF) Mounted Drives — Sizes 5107 thru 5608
Screw Conveyor (JSC) Drives — Sizes 5107 thru 5407

TABLE 4

HP	Output rpm	Drive Size	Min H.S.S. Sheave Pitch Dia †	HP	Output rpm	Drive Size	Min H.S.S. Sheave Pitch Dia †	HP	Output rpm	Drive Size	Min H.S.S. Sheave Pitch Dia †	HP	Output rpm	Drive Size	Min H.S.S. Sheave Pitch Dia †	
1/4	350-191	5107J_05	1.7	5	350-250	5107J_05	2.8	20 Cont	31-21	5407J_25	7.0	75	350-291	5315J_05	10.6	
	190-126	5107J_09	1.7		249-191	5107J_05	3.6		20-16	5415J_25	8.0		290-244	5315J_05	16.6	
	125-71	5107J_14	1.7		190-131	5107J_09	2.2		15-10	5507J_25	8.0		243-126	5407J_05	11.6	
	70-7	5107J_25	1.8		130-126	5115J_09	2.0		9-7	5608J_25	9.5		125-101	5407J_14 †	7.2	
	6-5	5115J_25	2.0		125-71	5115J_14	2.0		25	350-191	5215J_05		8.2	100-85	5407J_14 †	8.5
1/3	350-191	5107J_05	1.7		70-69	5115J_25	2.6	190-126		5215J_09	6.0	84-71	5415J_14 †	10.5		
	190-126	5107J_09	1.7		68-43	5203J_25	4.0	125-81		5215J_14	6.0	70-61	5415J_25 †	8.0		
	125-71	5107J_14	1.7		42-27	5207J_25	5.0	80-71		5307J_14	7.0	60-39	5507J_25 †	8.0		
	70-9	5107J_25	1.9		26-16	5215J_25	6.0	70-50		5307J_25	7.0	38-26	5608J_25	9.5		
	8-5	5115J_25	2.3		15-10	5307J_25	7.0	49-39	5315J_25	7.0	100	350-251	5407J_05 †	10.8		
1/2	350-191	5107J_05	1.7		9-8	5315J_25	7.0	38-26	5407J_25	7.0		250-201	5407J_05	10.7		
	190-126	5107J_09	1.7		7-5	5407J_25	7.0	25-20	5415J_25	8.0		200-151	5407J_05	17.8		
	125-71	5107J_14	1.7		7-1/2	350-329	5107J_05	3.7	19-13	5507J_25		8.0	150-136	5407J_05	21.9	
	70-13	5107J_25	2.0			328-191	5115J_05	4.2	12-9	5608J_25		9.5	135-114	5407J_14 •	7.0	
	12-7	5115J_25	2.5			190-126	5115J_09	2.2	30	350-225	5215J_05	12.3	113-82	5415J_14 †	12.2	
6-5	5203J_25	4.0	125-105	5115J_14		2.0	224-211	5215J_05		18.9	81-71	5507J_14 †	11.8			
3/4	350-191	5107J_05	1.7	104-71		5203J_14	4.0	210-191		5307J_05	7.0	70-52	5507J_25 †	8.0		
	190-126	5107J_09	1.7	70-41	5207J_25	5.0	190-126	5215J_09		6.0	51-35	5608J_25 †	10.0			
	125-71	5107J_14	1.7	40-24	5215J_25	6.0	125-97	5215J_14		6.5	125	350-271	5407J_05 †	14.0		
	70-19	5107J_25	2.1	23-15	5307J_25	7.0	96-71	5307J_14	7.0	270-231		5407J_05 †	18.1			
	18-11	5115J_25	2.4	14-12	5315J_25	7.0	70-60	5307J_25	7.0	230-191		5415J_05 †	18.3			
10-7	5203J_25	4.0	11-8	5407J_25	7.0	59-47	5315J_25	7.0	190-156	5415J_05		17.3				
6-5	5207J_25	5.0	7-6	5415J_25	8.0	46-32	5407J_25	7.0	155-146	5415J_05		19.7				
1	350-191	5107J_05	1.7	5	5507J_25	8.0	31-24	5415J_25	8.0	145-136	5415J_05	23.0				
	190-126	5107J_09	1.7	10	350-301	5115J_05	4.2	23-16	5507J_25	8.0	135-126	5507J_05	11.0			
	125-71	5107J_14	1.7		300-226	5115J_05	6.1	15-11	5608J_25	9.5	125-103	5415J_14 †	8.0			
	70-25	5107J_25	2.1		225-191	5115J_05	9.8	40	350-332	5215J_05	14.0	102-71	5507J_14 †	14.8		
	24-14	5115J_25	2.5		190-150	5115J_09	2.8		331-191	5307J_05	10.1	70-65	5507J_25 †	8.0		
13-9	5203J_25	4.0	149-126		5203J_09	4.8	190-132		5215J_09 †	12.9	64-44	5608J_25 †	10.8			
8-6	5207J_25	5.0	125-88	5203J_14	6.8	131-126	5307J_09		11.6	150	350-301	5415J_05 †	13.3			
5	5215J_25	6.0	87-71	5207J_14	5.0	125-80	5307J_14		7.0		300-251	5415J_05 †	16.0			
1-1/2	350-191	5107J_05	1.7	70-54	5207J_25	5.0	79-71	5315J_14	7.9		250-225	5415J_05 †	17.8			
	190-126	5107J_09	1.7	53-32	5215J_25	6.0	70-64	5315J_25	7.0		224-201	5415J_05 †	21.2			
	125-71	5107J_14	1.7	31-20	5307J_25	7.0	63-43	5407J_25	7.0		200-126	5507J_05	16.0			
	70-38	5107J_25	2.0	19-16	5315J_25	7.0	42-33	5415J_25	8.0	125-78	5507J_14 •	8.9				
	37-21	5115J_25	2.5	15-11	5407J_25	7.0	32-21	5507J_25	8.0	77-71	5608J_14 •	9.5				
2	20-13	5203J_25	4.0	10-8	5415J_25	8.0	20-14	5608J_25	9.5	70-54	5608J_14 †	12.2				
	12-8	5207J_25	5.0	7-5	5507J_25	8.0	50	350-251	5307J_05	11.3	200	350-321	5507J_05 •	8.0		
	7-5	5215J_25	6.0	15	350-327	5115J_05		13.7	250-215	5307J_05		18.4	320-291	5507J_05 •	9.0	
	3	350-191	5107J_05		1.7	326-191		5207J_05	7.2	350-191		5315J_05	8.0	290-261	5507J_05 •	10.3
		190-126	5107J_09		1.7	190-162		5203J_09	13.8	190-176		5215J_09 †	14.0	260-217	5507J_05 •	13.1
125-71		5107J_14	1.7		161-126	5207J_09		5.0	175-126	5315J_09 †		10.6	111-110	5507J_14 •	10.1	
70-50		5107J_25	2.1		125-81	5207J_14	7.5	125-100	5307J_14 †	9.7	105-86	5608J_14 •	9.6			
49-28		5115J_25	2.5	80-71	5215J_14	6.0	99-80	5315J_14	12.0	60	350-191	5315J_05	13.2			
27-17	5203J_25	4.0	70-48	5215J_25	6.0	79-71	5407J_14	7.0	190-151		5315J_09 †	12.1				
16-11	5207J_25	5.0	47-30	5307J_25	7.0	70-53	5407J_25 †	7.0	150-126		5315J_09 †	17.2				
10-7	5215J_25	6.0	29-24	5315J_25	7.0	52-41	5415J_25	8.0	125-105		5315J_14 †	14.0				
6-5	5307J_25	7.0	23-16	5407J_25	7.0	40-26	5507J_25	8.0	104-99		5315J_14 †	16.4				
3	350-191	5107J_05	2.1	15-12	5415J_25	8.0	25-18	5608J_25	9.5	98-71	5407J_14 †	8.1				
	190-126	5107J_09	1.7	11-8	5507J_25	8.0	20	70-65	5407J_25 †	7.0	70-65	5407J_25 †	7.0			
	125-80	5107J_14	1.7	7-5	5608J_25	9.5		64-49	5415J_25 †	8.0	48-31	5507J_25	8.0			
	79-71	5115J_14	2.0	20	350-301	5207J_05		6.4	30-21	5608J_25	9.5	30-21	5608J_25	9.5		
	70-41	5115J_25	2.6		300-251	5207J_05		12.8	350-191	5315J_05	13.2	70	350-191	5315J_05	13.2	
40-26	5203J_25	4.0	250-191		5215J_05	6.0		190-151	5207J_09	8.6	190-151		5207J_09	8.6		
25-17	5207J_25	5.0	190-151		5207J_09	13.7	150-131	5207J_09	13.7	150-131	5207J_09		13.7			
16-10	5215J_25	6.0	130-126		5207J_09	16.4	190-126	5215J_09	6.0	130-126	5207J_09		16.4			
9-6	5307J_25	7.0	190-126	5215J_09	6.0	125-120	5207J_14	8.0	190-126	5215J_09	6.0					
5	5315J_25	7.0	119-71	5215J_14	6.0	119-71	5215J_14	6.0	119-71	5215J_14	6.0					
				70-65	5215J_25	6.0	70-65	5215J_25	6.0	70-65	5215J_25	6.0				
				64-40	5307J_25	7.0	64-40	5307J_25	7.0	64-40	5307J_25	7.0				
				39-32	5315J_25	7.0	39-32	5315J_25	7.0	39-32	5315J_25	7.0				

★ Horizontal Drives – Selections shown in bold type require cooling as indicated by footnotes † and • below. Refer to Engineering 377-114 for maximum output speeds.

Vertical Drives – Make selection from Table 3 and then refer to Engineering 377-114 to determine drive speed limits with and without cooling.

† Values are for V-Belt drives and load applied one shaft diameter from seal cage or fan if so equipped. For minimum sheave diameters for other axial locations, refer to load location factor table on Page 15. Multiply values by 0.66 when using timing belt or chain drives.

‡ Shaft driven fan required.

• Electric fan required.

Engineering Data

Ratio Substitutions — The selection tables list the most economical choice of drive size and ratio for a given output speed based on 1750 and 1170 rpm motors. Where required, a substitute gear ratio may be used in the selected drive size providing it is double reduction and . . .

- The ratio substitution is one of the following:
14:1 for 25:1 9:1† for 25:1 9:1‡ for 14:1

- The hollow shaft speed for the substitute ratio does not exceed the maximum rpm shown in the dimensions pages.
- The resulting sheave ratio is practical.
- The high speed sheave meets the minimum pitch diameter requirements shown in Table 5.

† A 9:1 ratio substitution is available for Sizes 5107 thru 5307 only.

TABLE 5 — Ratio Substitutions

Minimum High Speed Shaft Sheave Pitch Diameter For Gear Drive Ratio Substitutions

DRIVE SIZE	14:1 For 25:1 Ratio						9:1 For 25:1 Ratio						9:1 For 14:1 Ratio					
	Load Class & Motor HP			Min Sheave Pitch Dia ★	Min Sheave Pitch Dia ★	Min Sheave Pitch Dia ★	Load Class & Motor HP			Min Sheave Pitch Dia ★	Min Sheave Pitch Dia ★	Min Sheave Pitch Dia ★	Load Class & Motor HP			Min Sheave Pitch Dia ★	Min Sheave Pitch Dia ★	Min Sheave Pitch Dia ★
	I	II	III				I	II	III				I	II	III			
5107	1/4-2 3	1/4-2 3	1/4-2 ...	1.7 1.7	1.7 1.7	1.7	1/4-3 ...	1/4-3 ...	1/4-2 ...	2.3	1.7	1.7	1/4-3 7 1/2	1/4-3 5	1/4-3 ...	1.7 2.1	1.7 1.7	2.1
5115	1/2 - 3 5-7 1/2	1/4-3 5	1/4-3 5	2.0 2.0	2.0 2.0	2.0	1/2-3 5-7 1/2	1/3-2 3-5	1/4-2 3-5	2.0 2.7	2.6 2.6	2.6 2.7	5-7 1/2 10-15	5-7 1/2 10	3-7 1/2 ...	2.2 2.8	2.6 2.6	2.6
5203	3/4-10 ...	3/4-10 ...	1/2-5 ...	4.0	4.0	4.0	3/4-5 7 1/2-10	3/4-5 7 1/2-10	1/2-5 ...	4.0 6.3	4.0 6.6	5.8	10 15	10 ...	7 1/2 10	4.0 11.8	5.0	7.1 16.6
5207	1 1/2-10 15-20	1-7 1/2 10-15	3/4-5 7 1/2-10	5.0 5.4	5.0 5.0	5.0	1 1/2-10 15-20	1-7 1/2 10-15	3/4-5 7 1/2-10	6.1 10.8	6.2 9.6	6.3 9.4	15-20 25	15 20	10 ...	7.0 16.1	5.2 14.6	5.0
5215	2-30 ...	1 1/2-30 ...	1-20 ...	6.0	6.1	6.0	2-15 20-30	1 1/2-15 20-30	1-15 20	6.0 6.0	6.0 6.4	6.0 7.8	25-40 50	20-40 30	15-25 30	6.0 9.6	7.0 11.3	6.6 7.7
5307	3-25 30-50	3-25 30-50	2-30 ---	7.0 8.2	7.0 7.0	7.0	3-20 25-30	3-15 20-25	2-15 20	8.8 14.1	8.1 14.6	13.2 18.8	40 50	40 ...	25 30	7.0 13.4	12.1	9.2 19.2
5315	5-50 60-75	5-30 40-60	3-25 30-40	8.8 12.3	7.0 11.9	7.0												
5407	7 1/2-100 ...	7 1/2-75 ...	3-60 ...	8.9†	8.8†	8.8†												
5415	10-40 50-125	7 1/2-40 50-125	7 1/2-30 40-75	8.0 12.2†	8.0 12.6†	8.0												
5507	15-75 100-150	15-75 100-150	7 1/2-60 75-125	8.0 16.0†	8.0 16.3†	8.0												
5608	20-100 150-250	15-100 125-200	15-75 100-150	9.5 17.7†	9.5 14.5†	9.5												

★ Values are for V-belt drives with load applied one shaft diameter from seal cage. For minimum sheave diameters for other axial locations, refer to load location factor table on page 15. Multiply values by 0.66 when using timing belt or chain drives.

† Load applied one shaft diameter from Fan Hub.

Motor Ratings and Dimensions are in accordance with NEMA standards

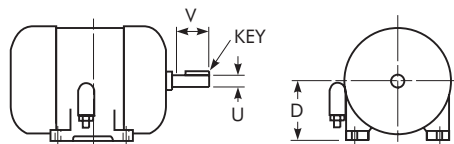

TABLE 6 — 1964 (Type T) NEMA Motor Standards †

MOTOR SPEED AND FRAME SIZE										MOTOR SHAFT DIMENSIONS — INCHES																
Motor hp	1800 rpm	1200 rpm	900 rpm	Motor hp	1800 rpm	1200 rpm	900 rpm	Motor hp	1800 rpm	1200 rpm	900 rpm	Motor Frame	D	U	V	Key (Sq)	Motor Frame	D	U	V	Key (Sq)	Motor Frame	D	U	V	Key (Sq)
1/2	56	56	143	7 1/2	213	254	256	50	326	365	404	56	3 1/2	5/8	2	3/16	215	5 1/4	1 3/8	3 1/8	5/16	326	8	2 1/8	5	1/2
3/4	56	143	145	10	215	256	284	60	364	404	405	143	3 1/2	7/8	2	3/16	254	6 1/4	1 5/8	3 3/4	3/8	364	9	2 3/8	5 5/8	5/8
1	143	145	182	15	254	284	286	75	365	405	...	145	3 1/2	7/8	2	3/16	256	6 1/4	1 5/8	3 3/4	3/8	365	9	2 3/8	5 5/8	5/8
1 1/2	145	182	184	20	256	286	324	100	404	182	4 1/2	1 1/8	2 1/2	1/4	284	7	1 7/8	3/8	1/2	404	10	2 7/8	7	3/4
2	145	184	213	25	284	324	326	125	405	184	4 1/2	1 1/8	2 1/2	1/4	286	7	1 7/8	3/8	1/2	405	10	2 7/8	7	3/4
3	182	213	215	30	286	326	364	150	444	213	5 1/4	1 3/8	3 1/8	5/16	324	8	1 7/8	5	1/2	444	11	3 3/8	8 1/4	7/8
5	184	215	254	40	324	364	365	200	445	445	11	3 3/8	8 1/4	7/8

† Frame numbers listed are for 110, 208, 220/440 and 550 volts. Falk Motor Mounts are pre-drilled for related 1964 NEMA standard foot-mounted motors.

Engineering Data

Overhung Load at Hollow Shaft †

OVERHUNG LOADS — Overhung load is imposed upon a shaft when a pinion, sprocket or sheave is used as a power take-off. The magnitude of the load varies with the type of take-off and its proximity to the shaft bearing. Calculate the load (including minimum required service factor) and check the result against the tabulated overhung load rating. The overhung load formula below considers the transmitted horsepower without service factor. This is appropriate for applications where starting loads, momentary overloads and brake capacities do not exceed 200% of drive rating (100% overload). For other conditions, compute the equivalent power by multiplying the transmitted power by the appropriate service factor.

$$\text{Overhung Load} = \frac{126,000 \times \text{hp} \times F_c \times L_f}{\text{Pitch Dia} \times \text{rpm}}$$

F_c = Load Connection Factor

- Sprocket ★ 1.00
- Synchronous (timing) Belts 1.30
- V-Belt. 1.50
- Machined Pinion & Gear ★ 1.25
- Flat Belt 2.50

★ Refer all multiple chain sprocket and pinion mounted applications to Falk for deflection analysis.

L_f = Load Location Factor

Select L_f from Table 7, under drive size and opposite distance from end of hollow shaft.

Locate the center line of the load as close to the drive seal cage as practical to minimize the effect of the overhung load and increase bearing life.

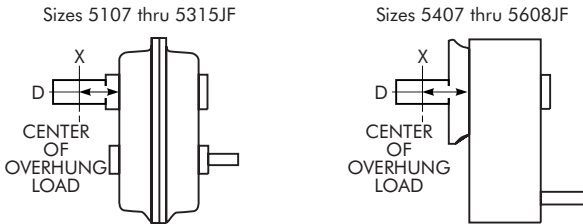

Consult Factory for Higher Overhung Load Ratings — In many cases, overhung load capacity in excess of that published is available. If the actual load should exceed the published capacity, refer full details to Falk; provide complete application information (see Page 7), as well as direction of rotation, location and direction of applied load.

EXAMPLE — A chain drive requiring 10 hp is being driven by a 5207JF14, 100 rpm output, using a single-width, 21-tooth, 8.4" pitch diameter sprocket mounted on a low speed stub shaft. Center line of the load is 4" from the output face of the housing.

PROCEDURE: F_c = 1.00 L_f = 1.08

$$\text{Overhung Load} = \frac{126,000 \times 10 \times 1.00 \times 1.08}{8.4 \times 100} = 1620 \text{ lb}$$

Since the overhung load capacity shown for a 5207JF14 drive at 100 rpm is 2730 pounds, the application is satisfactory.

TABLE 7 — Load Location Factor (L_f) For Load Located at Dimension "X" Below

Distance D ★ Inches	DRIVE SIZE										
	5107	5115	5203	5207	5215	5307	5315	5407	5415	5507	5608
2	0.93	0.86	0.84	0.83	0.80	0.76	0.76				
3	1.13	0.99	0.96	0.94	0.89	0.85	0.84	0.72			
4	1.37	1.19	1.14	1.08	0.99	0.94	0.92	0.79	0.77	0.74	0.72
5	1.62	1.40	1.33	1.26	1.14	1.04	1.00	0.86	0.83	0.80	0.77
6	...	1.60	1.53	1.44	1.29	1.18	1.13	0.94	0.89	0.85	0.82
7	1.62	1.45	1.32	1.27	1.02	0.95	0.91	0.87
8	1.46	1.40	1.14	1.02	0.97	0.92
10	1.67	1.38	1.23	1.14	1.02
12	1.94	1.62	1.43	1.33	1.19
16	1.85	1.71	1.53

★ Distance "D" is in inches from the output face of the housing. Interpolate for L_f factors at intermediate distances. For example, L_f is 1.11 for Size 5307 when distance is 5.50 inches. Refer to Factory for distances greater than those shown.

† **NOTE:** For JF Flanged Mounted Drives, the TA Taper bushing, using the spanner nut, is not intended to provide the full external load capacities given in Tables 8 & 9. Use the tapered driven shafts manufactured per Manual 377-140, or non-tapered driven shafts and bushings per Manual 377-142 (5107-5315JF) & 377-144 (5407-5608JF), or refer your application to Factory for review.

TABLE 8 — Guide To Low Speed Shaft Overhung Load Capacity – lb ‡

Consult Factory For Higher Overhung Load Ratings

DRIVE SIZE	Ratios 9:1, 14:1 or 25:1							Ratio 5:1					
	Output Speed – rpm												
	10	25	50	75	100	125	150	175	90	200	300	350	
Overhung Load At Dimension "X" Below													
5107	3660	2720	2150	1870	1700	1600	1520	1460	1900	1490	1310	1250	
5115	4370	3240	2540	2200	1990	1850	1750	1670	2200	1720	1520	1450	
5203	4170	3010	2360	2050	1860	1740	1630	1516	2020	1580	1390	1330	
5207	6240	4440	3450	3000	2730	2540	2400	2280	3120	2430	2150	2050	
5215	9530	6950	5420	4710	4310	4050	3860	3700	4770	3730	3300	3140	
5307	8860	6300	4810	4090	3730	3470	3270	3110	4460	3470	3060	2910	
5315	10000	8700	6630	5740	5260	4040	3757	3494	6190	4850	4280	4090	
5407	9500	9120	6940	5940	5370	4960	6010	4620	4090	3910	
5415	15000	13210	10080	8610	7750	7160	9190	7200	6370	6070	
5507	Refer to Factory									
5608	Refer to Factory									

‡ Published values of low speed shaft overhung load are for loads applied one shaft diameter from the seal cage with a service factor of unity. Where overhung load is proportional to torque (i.e. pinion, sprocket, or sheave applications) an appropriate service factor should be considered in the overhung load calculation.

Driven Shaft Diameter Tolerances

Shaft diameters shall be within commercial tolerances for turned and polished round bars as shown below.

Shaft Diameter	Maximum Undersize Variation – Inches
to 1.50	0.004
over 1.50 to 2.50 incl.	0.005
over 2.50 to 4 incl.	0.006
over 4 to 6 incl.	0.007
over 6 to 8 incl.	0.008

Keys and keyways in the supporting shaft shall be in accordance with ANSI B17.1 for size, depth, offset, lead, and parallelism.

Engineering Data

Sizes 5107 thru 5315JF

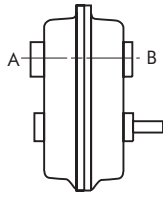

Sizes 5407 thru 5608JF

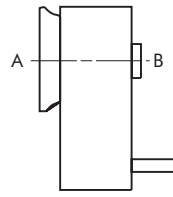

Thrust at Hollow Shaft

The capacities in Table 9 are for PURE thrust loads for either direction of shaft rotation. Higher values are listed in Manual 377-115 for specific shaft rotations. When both radial and thrust loads are involved, refer application details to the Factory.

TABLE 9 — Guide To Pure Thrust Capacity At Hollow Shaft – lb

JF & JFV DRIVE SIZE	Ratios 9:1, 14:1 or 25:1								Ratio 5:1				JF & JFV DRIVE SIZE	Ratios 9:1, 14:1 or 25:1								Ratio 5:1			
	Output Speed – rpm								Output Speed – rpm					Output Speed – rpm								Output Speed – rpm			
	10	25	50	75	100	125	150	175	90	200	300	350		10	25	50	75	100	125	150	175	90	200	300	350
Thrust: A towards B												Thrust: B towards A													
5107	3590	2840	2150	1820	1620	1540	1470	1420	2060	1610	1410	1350	5107	3490	2840	2160	1820	1620	1540	1470	1420	2060	1610	1410	1350
5115	4390	4390	4350	3680	3250	3020	2860	2730	3920	3060	2700	2570	5115	3490	3490	3490	3490	3270	3040	2870	2740	3490	3070	2700	2580
5203	6680	5680	4310	3670	3290	3060	2850	2720	3800	2940	2580	2460	5203	5590	5590	4410	3760	3380	3150	2940	2800	3880	3000	2640	2510
5207	8120	7750	5760	4930	4450	4120	3860	3640	5600	4340	3830	3660	5207	5590	5590	5590	5100	4610	4240	4000	3780	5590	4440	3920	3740
5215	10180	10180	9900	8440	7690	7270	6960	6720	9130	7120	6260	5980	5215	8170	8170	8170	8170	7900	7460	7140	6890	8170	7250	6380	6090
5307	13160	11010	8240	6750	6100	5640	5300	5010	8440	6500	5690	5410	5307	10770	10770	8640	7080	6410	5940	5570	5270	8660	6680	5850	5560
5315	13220	8470	6070	5050	4660	4370	4064	3780	5910	4660	4100	3420	5315	13680	8640	6230	5260	4830	4530	4213	3918	6060	4780	4280	4020
5407	13000	9810	6320	5520	4890	4370	6230	4830	4270	4070	5407	12210	9890	6900	5600	4960	4440	6290	4730	4190	4010
5415	16400	16400	14730	12100	10630	9630	14590	11400	10070	9590	5415	18980	18980	14730	12100	10630	9680	14590	11200	9990	9530
5507	6000	6000	6000	6000	6000	6000	5507	20580	20580	15230	13190	12160	11420
5608	14800	14800	14800	14300	13425	12554	5608	29000	23580	15810	13990	13122	12271

TABLE 10 — WR² (lb-in²) Referred to H.S. Shaft

DRIVE SIZE	Ratio				DRIVE SIZE
	5:1	9:1	14:1	25:1	
5107	1.37	1.28	0.83	0.43	5107
5115	3.45	3.14	2.08	1.07	5115
5203	7.03	5.94	3.59	2.00	5203
5207	15.01	12.86	8.34	4.70	5207
5215	39.02	35.69	19.57	10.92	5215
5307	70.67	63.63	34.96	20.82	5307
5315	82.89	72.42	47.18	28.62	5315
5407	171.83	...	74.86	41.94	5407
5415	275.77	...	140.58	74.51	5415
5507	262.79	137.81	5507
5608	457.90	232.40	5608

TABLE 10 — Values shown in Table 10 above are referred to the drive high speed shaft. The WR² referred to the hollow (low speed) shaft equals the exact total ratio squared times the H.S. shaft WR². Refer to Factory for values of unlisted ratios and drive sizes.

TABLE 11 — Minimum sheave diameters listed in Tables 2, 3 & 4 are for V-belt drives with the load applied one shaft diameter from the seal cage or from the fan guard, if equipped with a shaft cooling fan. For minimum sheave diameters for loads applied at a greater distance, multiply the published minimum sheave diameter by the load location factor (from Table 11) for the "distance" required. When using chains or timing belts, multiply minimum sheave diameters by 0.66.

TABLE 11 — H.S. Shaft Load Location Factors

Distance D in Inches †	DRIVE SIZE											
	5107	5115	5203	5207	5215	5307	5315	5407	5415	5507	5608	
.500	0.94											
.750	0.98	0.95										
.875	1.00	0.97										
1.000	1.05	0.98	0.95									
1.125	1.11	1.00	0.96	0.95								
1.250	1.16	1.05	0.98	0.97								
1.375	1.21	1.09	1.00	0.98	0.95							
1.500	1.27	1.14	1.04	1.00	0.96	0.94	0.93					
1.750	1.37	1.24	1.11	1.07	0.99	0.96	0.95	0.93	0.94			
1.875	1.43	1.28	1.15	1.10	1.00	0.98	0.96	0.94	0.95			
2.000	1.48	1.33	1.19	1.14	1.03	0.99	0.98	0.96	0.96	0.95	0.94	
2.125	...	1.38	1.23	1.17	1.06	1.00	0.99	0.97	0.97	0.96	0.94	
2.250	...	1.43	1.26	1.20	1.09	1.03	1.00	0.98	0.98	0.96	0.95	
2.500	...	1.52	1.34	1.27	1.15	1.08	1.05	1.00	1.00	0.98	0.97	
2.750	1.41	1.34	1.21	1.13	1.10	1.05	1.05	1.00	0.98	
3.000	1.49	1.41	1.27	1.19	1.15	1.11	1.10	1.05	1.00	
3.250	1.47	1.33	1.24	1.20	1.16	1.14	1.09	1.04	
3.500	1.54	1.39	1.30	1.25	1.21	1.19	1.14	1.09	
3.750	1.45	1.35	1.30	1.26	1.24	1.18	1.13	
4.000	1.51	1.40	1.35	1.32	1.29	1.23	1.17	
4.250	1.46	1.40	1.37	1.34	1.27	1.21	
4.500	1.51	1.45	1.42	1.38	1.32	1.26	
4.750	1.50	1.48	1.43	1.37	1.30	
5.000	1.55	1.53	1.48	1.41	1.34	
5.250	1.58	1.53	1.46	1.39	
5.500	1.63	1.58	1.50	1.43	
5.750	1.69	1.62	1.55	1.47	
6.000	1.74	1.67	1.60	1.51	
6.250	1.72	1.64	1.56	
6.500	1.69	1.60	
6.750	1.73	1.64	
7.000	1.78	1.69	
7.250	1.82	1.73	
7.500	1.87	1.77	
7.750	1.81	
8.000	1.86	
8.250	1.90	

† Distance "D" is in inches from the input face of the H.S. seal cage. Interpolate for load location factors at intermediate distances. For example, the load location factor is 1.27 for Size 5307 when distance is 3.375 inches. Refer to Factory for distances greater than those shown.

Size 5107/Dimensions – Inches

Shaft Mounted (JR) & Flange Mounted (JF) Drive ★

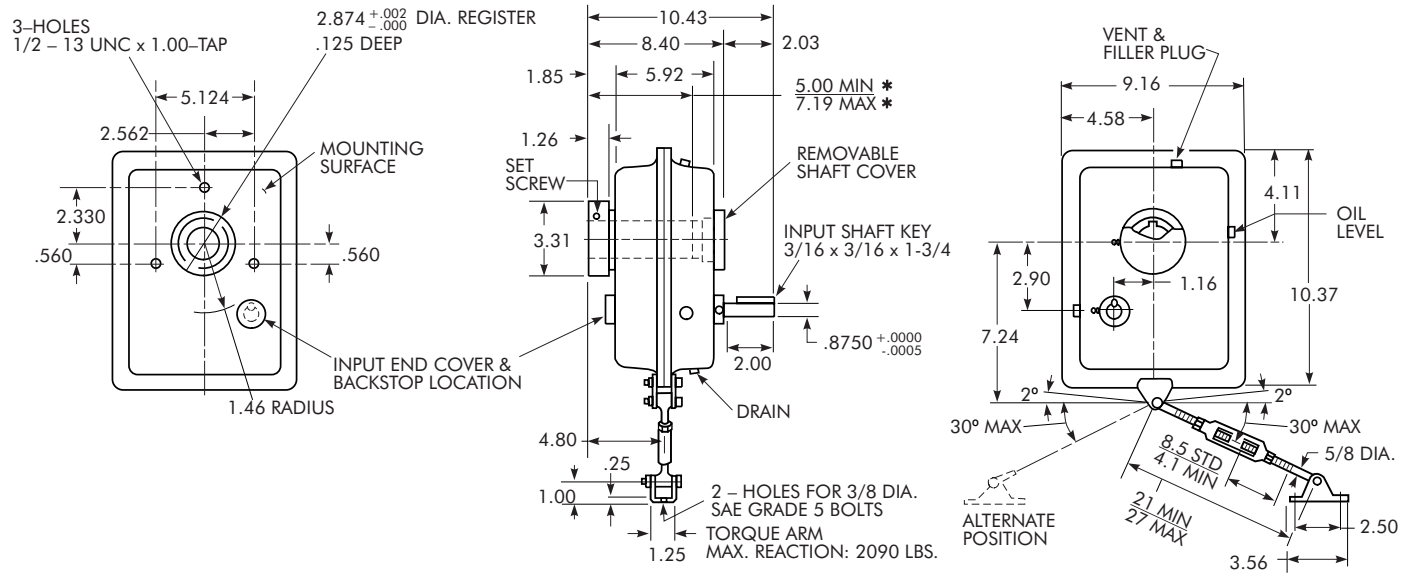

Hollow Shaft Details

See Manual 377-140 for JF drive tapered driven shaft recommendations. See Manual 377-142 for JF drives using tapered bushings.

Angular Limits For Horizontal Mounting

(All Clock Positions)
 Refer to Factory for lubrication analysis of all inclined drives exceeding the maximum specified below. Also for drives with combined incline down and rotation.

BASIC DRIVE SIZE †	Part Number	Exact Ratio	Max Output rpm	Wt lb
5107J05A	0793781	5.077	350	25
5107J09A	0793782	9.462	190	30
5107J14A	0793783	14.43	125	30
5107J25A	0793784	25.81	70	30

* MIN = Minimum required projection of driven shaft.
 MAX = Maximum projection of driven shaft which allows for use of thrust plate.
 † JR = Basic Drive + Bushing + Torque Arm
 JF = Basic Drive (Bushing Optional)
 JSC = Basic Drive + Seal Housing + Drive Shaft

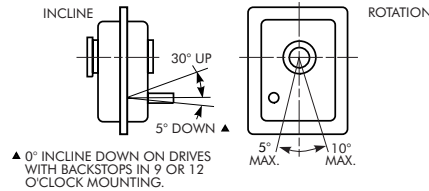
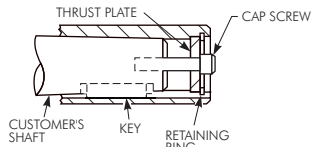

TA Taper Bushings

Style No. 1 — Thin-wall bushing

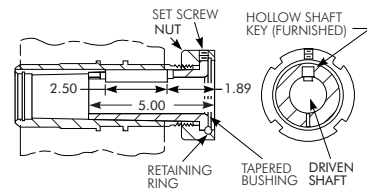

Style No. 2 — Thick-wall bushing

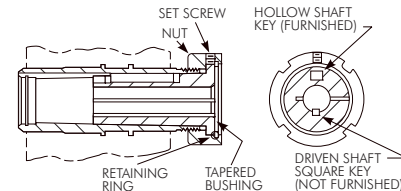

BUSHING SIZE	Part Number ‡	Style No.	Driven Shaft Keyway/Min Key Length •	Wt lb
BU5107J-1.000	0769061	2	1/4 x 1/8 x 2 1/2	2.1
BU5107J-1.125	0769062	2	1/4 x 1/8 x 2 1/4	1.8
BU5107J-1.188	0769063	2	1/4 x 1/8 x 2	1.6
BU5107J-1.250	0769064	1	1/4 x 1/8 x 2 1/2	1.5
BU5107J-1.375	6720659	1	3/8 x 3/16 x 2 1/2	1.0
BU5107J-1.438	0769065	1	3/8 x 3/16 x 2 1/2	1.0

‡ Consists of bushing, drive key, nut, retaining ring and setscrew.
 • Check strength of driven shaft and unfurnished key.

Accessories

Torque Arm

TA5107J
 PN 0785261
 Wt. 4 lb.

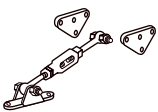

Backstop

BS5107J05/09/14
 PN 0738495
 BS5107J25
 PN 0738496
 Wt. 1 lb.



Thrust Plate Kit

TP5107J
 PN 0769060
 Wt. 1 lb.



Vertical Breather

VB5107J-HSS Up
 PN 0738540
 VB5107J-HSS Down
 PN 0738553
 Wt. 6 lb.



Vertical Drives

Refer to Factory for lubrication analysis of all vertical drives exceeding ±1° from true vertical.

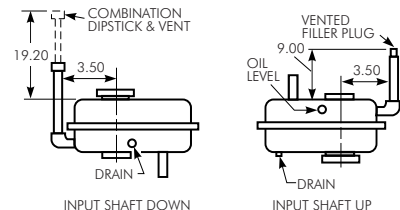

Size 5107/Dimensions – Inches

Screw Conveyor (JSC) Drive ★

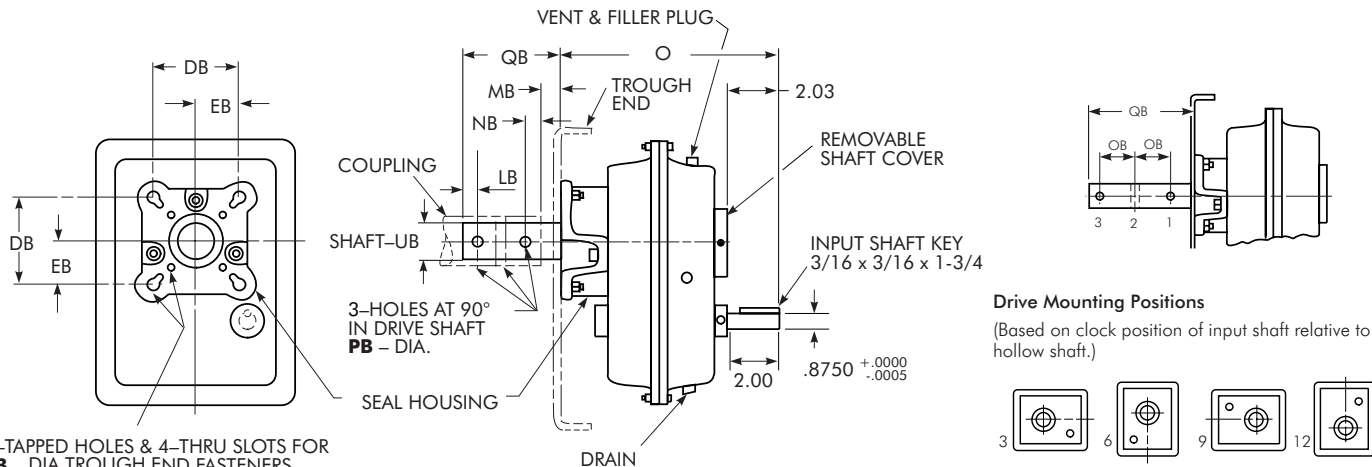

4-TAPPED HOLES & 4-THRU SLOTS FOR FB - DIA TROUGH END FASTENERS

BASIC DRIVE SIZE ★	Screw Conveyor Components										O	DB	EB	FB ▲	LB	MB	NB	OB	PB	QB	UB †
	Cplg Dia	Screw Dia	Max Tq lb-in	Drive Shaft w/Thrust Plate ‡	Part No.	Trough Spacer	Wt lb	Seal Housing	Part No.	Wt lb											
5107	1.500	6, 9	3,900	DS5107J-1.500	6720046	...	8	SH5107J	0769058	15	12.60	4.000	2.000	.500	.875	1.250	.875	3.000	.531	6.000	1.500
	2.000	9, 12	3,900	DS5107J-2.000	6720047	...	10	SH5107J	0769058	15	12.60	5.125	2.562	.625	.875	1.250	.875	3.000	.656	6.000	2.000
	2.437	12, 14	3,900	DS5107J-2.437	6720048	0752578	14	SH5107J	0769058	15	12.86	5.625	2.812	.625	.938	1.812	.938	3.000	.656	6.688	2.437
	3.000	12-20	3,900	DS5107J-3.000	6720049	0752578	18	SH5107J	0769058	15	12.86	6.000	3.000	.750	1.000	1.875	1.000	3.000	.781	6.875	3.000

★ Dimensions are for reference only and are subject to change without notice unless certified.
 ▲ Hexagon head screws with UNC thread are furnished by Falk for mounting the gear drive to the trough end.
 † Shaft diameters under 3" are held to limits of +.000", -.002". Shaft diameters 3" and over are held to limits of +.000", -.003".
 ‡ See Page 41 for optional 316 stainless steel drive shafts – stocked.

Trough End Seals

Waste Packing	Lip Seal	Packing Gland Seal Kit	Packing Gland Seal (Only)
Std.-Included with seal housing PN 0925058 Wt. 1 lb.	PN 2905318 Wt. 1 lb.	PGSK5107J PN 0769059 Wt. 1 lb.	PG5107J PN 2109907 Wt. 1 lb.

Motor Mounts

Standard Horizontal Drive Assembly – (6 o'clock) ♦ (3-9-12 o'clock optional)

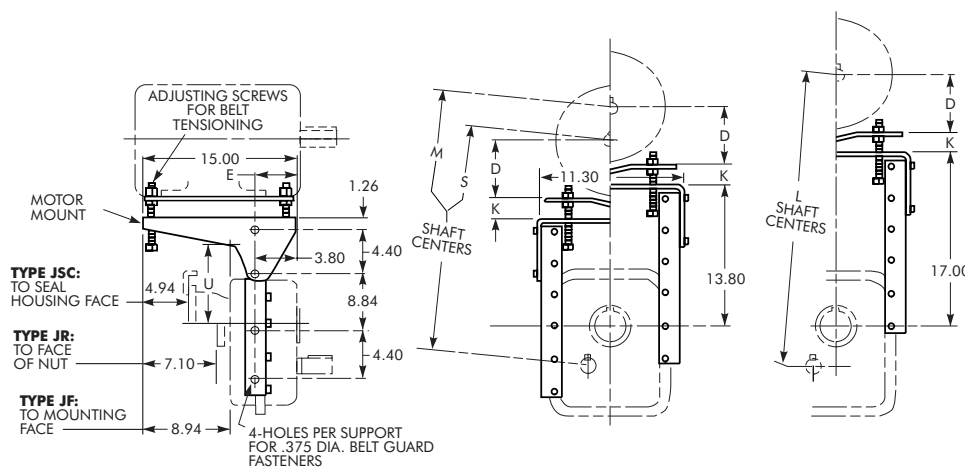

Frame	56	143-145T	182-184T	213-215T
D	3.50	3.50	4.50	5.25
E	2.50	2.00	2.50	3.25
Shaft Centers	Min-Max	Min-Max	Min-Max	Min-Max
(S) Short
(M) Medium	20.9-24.2	20.9-24.2	21.9-25.1	22.6-25.9
(L) Long	24.1-27.4	24.1-27.4	25.1-28.4	25.8-29.1

MOTOR MOUNT SIZE ●	Part Number	Type T Frame ■		K		U		Motor Mount Wt-lb
		Min	Max	Min	Max	Med	Long	
MM5107J-1	0738714	56	215	0.64	3.92	10.56	13.76	40

● Dimensions are for reference only and are subject to change without notice unless certified. When determining belt length for minimum shaft centers, follow the belt manufacturer's installation allowance recommendations.
 ■ Refer to Manual 377-820 for standard vertical assemblies and all Type U frame motor limits.
 ♦ Refer to Factory for alternate horizontal drive assemblies (high speed shaft over low speed).

Size 5115/Dimension -Inches

Shaft Mounted (JR) & Flange Mounted (JF) Drive ★

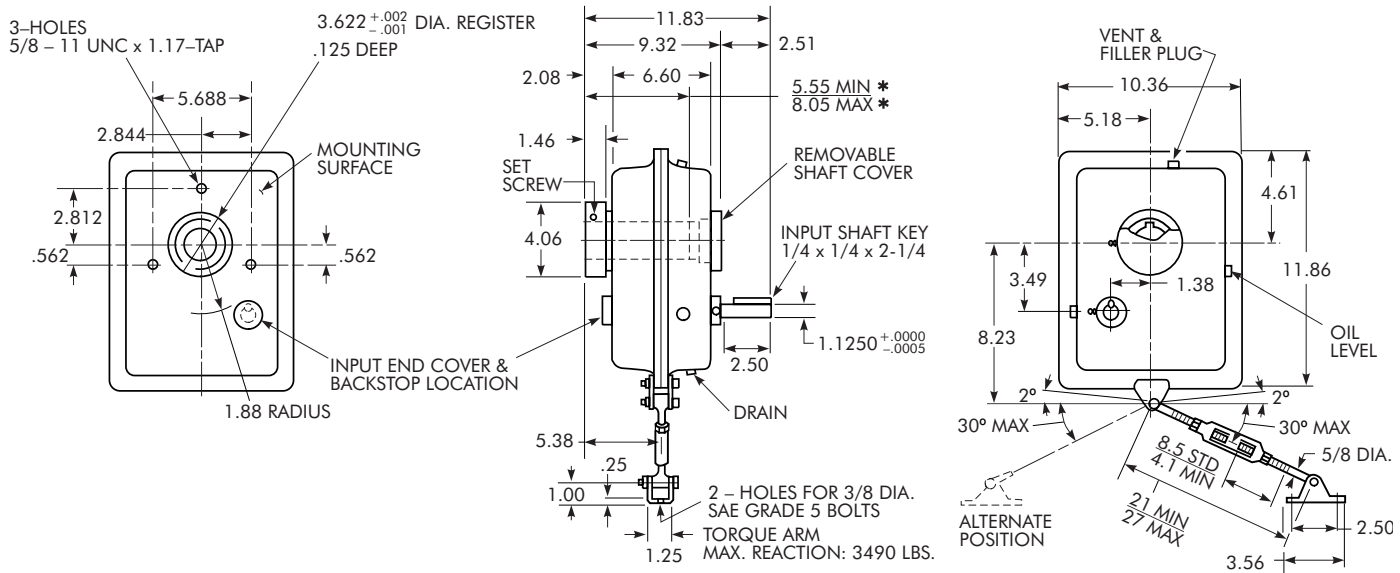

Hollow Shaft Details

See Manual 377-140 for JF drive tapered driven shaft recommendations. See Manual 377-142 for JF drives using tapered bushings.

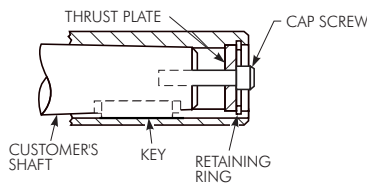

Angular Limits For Horizontal Mounting

(All Clock Positions)

Refer to Factory for lubrication analysis of all inclined drives exceeding the maximum specified below. Also for drives with combined incline down and rotation.

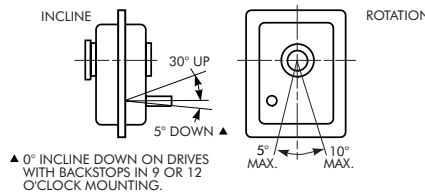

BASIC DRIVE SIZE †	Part Number	Exact Ratio	Max Output rpm	Wt lb
5115J05A	0793858	5.053	350	40
5115J09A	0793859	9.357	190	45
5115J14A	0793860	13.95	125	45
5115J25A	0793861	24.87	70	45

* † (See footnotes on Page 16.)

TA Taper Bushings

Style No. 1 — Thin-wall bushing

Style No. 2 — Thick-wall bushing

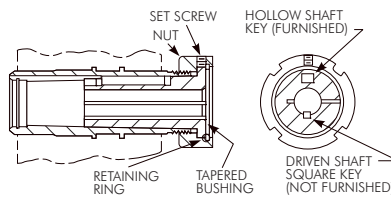
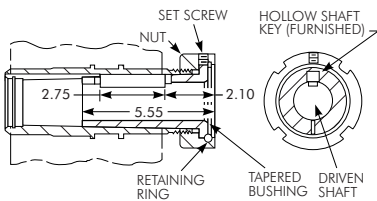

BUSHING SIZE	Part Number ‡	Style No.	Driven Shaft Keyway/Min Key Length •	Wt lb
BU5115J-1.188	0769077	2	1/4 x 1/8 x 4 1/4	4.3
BU5115J-1.250	0769078	2	1/4 x 1/8 x 4	4.1
BU5115J-1.438	0769079	2	3/8 x 3/16 x 2 1/4	3.5
BU5115J-1.500	0769080	2	3/8 x 3/16 x 2 1/4	3.3
BU5115J-1.625	0769081	1	3/8 x 3/16 x 2 3/4	2.9
BU5115J-1.688	0769082	1	3/8 x 3/16 x 2 3/4	2.7
BU5115J-1.750	0769083	1	3/8 x 3/16 x 2 3/4	2.4
BU5115J-1.938	0769084	1	1/2 x 1/4 x 2 3/4	1.7

‡ • (See footnotes on Page 16.)

Accessories

Torque Arm

TA5115J
 PN 0785261
 Wt. 4 lb.

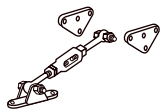

Backstop

BS5115J05/09/14
 PN 0738484
 BS5115J25
 PN 0738506
 Wt. 1 lb.



Thrust Plate Kit

TP5115J
 PN 0769076
 Wt. 1 lb.



Vertical Breather

VB5115J-HSS Up
 PN 0738540
 VB5115J-HSS Down
 PN 0738563
 Wt. 6 lb.



Vertical Drives

Refer to Factory for lubrication analysis of all vertical drives exceeding ±1° from true vertical.

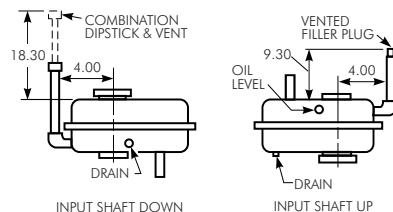

Size 5115/Dimensions – Inches

Screw Conveyor (JSC) Drive ★

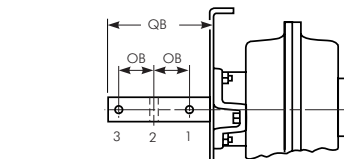
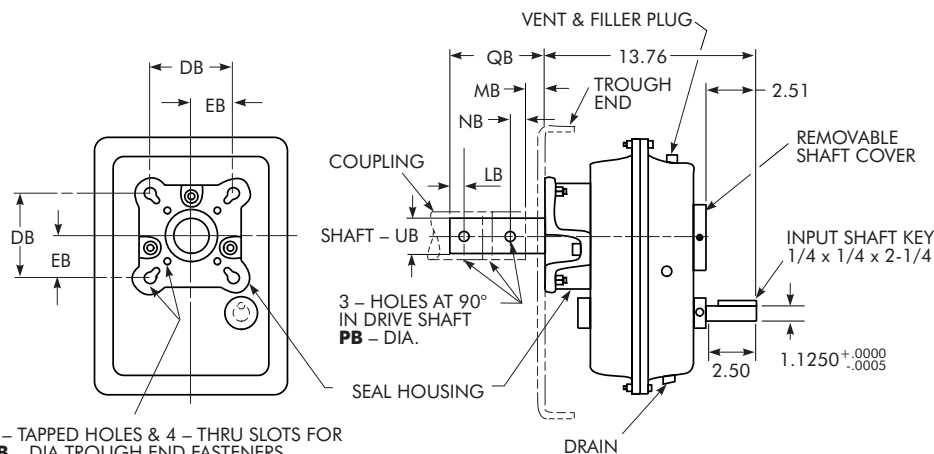

Drive Mounting Positions
(Based on clock position of input shaft relative to hollow shaft.)



4 – TAPPED HOLES & 4 – THRU SLOTS FOR FB – DIA TROUGH END FASTENERS

BASIC DRIVE SIZE ★	Screw Conveyor Components										DB	EB	FB ▲	LB	MB	NB	OB	PB	QB	UB †
	Cplg Dia	Screw Dia	Max Tq lb-in	Drive Shaft w/Thrust Plate ‡	Part No.	Wt lb	Seal Housing	Part No.	Wt lb											
5115	1.500	6, 9	5,200	DS5115J-1.500 *	6720050	14	SH5115J	0769074	14	4.000	2.000	.500	3.875	1.250	.875	3.000	.531	9.000 *	1.500	
	2.000	9, 12	6,800	DS5115J-2.000 *	6720051	14	SH5115J	0769074	14	5.125	2.562	.625	.875	1.250	.875	3.000	.656	6.000	2.000	
	2.437	12, 14	8,050	DS5115J-2.437	6720052	18	SH5115J	0769074	14	5.625	2.812	.625	.938	1.812	.938	3.000	.656	6.688	2.437	
	3.000	12-20	8,050	DS5115J-3.000	6720053	23	SH5115J	0769074	14	6.000	3.000	.750	1.000	1.875	1.000	3.000	.781	6.875	3.000	

★ ▲ † ‡ (See footnotes on Page 17.)

* Check drive shaft torque & bending capacity and coupling bolt shear & bearing stresses against load to be transmitted. See above drawing for location of third drive shaft-coupling bolt hole if required.

Trough End Seals

Waste Packing
Std.-Included
with seal housing
PN 0925058
Wt. 1 lb.

Lip Seal
PN 0912859
Wt. 1 lb.

Packing Gland Seal Kit
PGSK5115J
PN 0769075
Wt. 1 lb.

Packing Gland Seal (Only)
PG5115J
PN 1184314
Wt. 1 lb.

Motor Mounts

Standard Horizontal Drive Assembly – (6 o'clock) ♦ (3-9-12 o'clock optional)

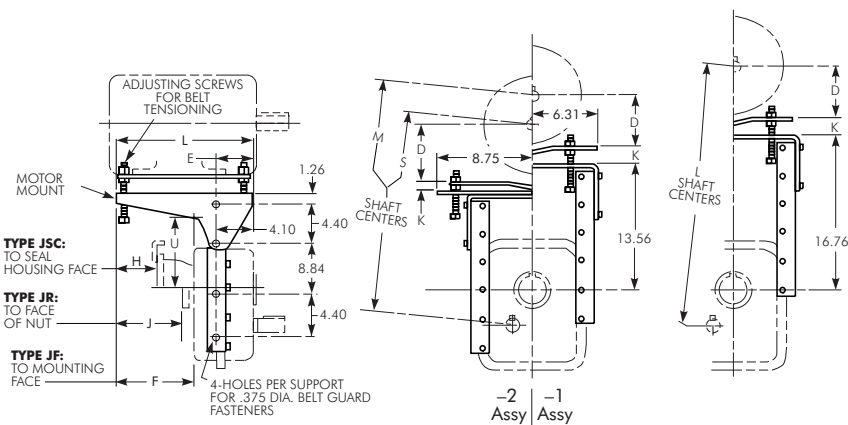

Frame	56	143-145T	182-184T	213-215T
D	3.50	3.50	4.50	5.25
E	2.50	2.00	2.50	3.25
Shaft Centers	Min-Max	Min-Max	Min-Max	Min-Max
(S) Short
(M) Medium	21.2-24.5	21.2-24.5	22.2-25.5	23.0-26.4
(L) Long	24.4-27.7	24.4-27.7	25.4-28.7	26.2-29.5
Frame	254-256T			
D	6.25			
E	4.00			
Shaft Centers	Min-Max			
(S) Short	...			
(M) Medium	24.6-28.3			
(L) Long	27.8-31.5♣			

♣ At 6 o'clock only.

MOTOR MOUNT SIZE ●	Part Number	Type T Frame ■		F	H	J	K		L	U			Motor Mount Wt-lb
		Min	Max				Min	Max		Short	Med	Long	
MMS115J-1	0738715	56	215	8.30	4.30	6.20	0.64	3.92	15.00	...	10.72	13.92	42
MMS115J-2	0786773	254	256	13.80	9.80	11.70	1.26	4.98	20.50	...	10.72	13.92	82

● ■ ♦ (See footnotes on Page 17.)

Size 5203/Dimensions – Inches

Shaft Mounted (JR) & Flange Mounted (JF) Drive ★

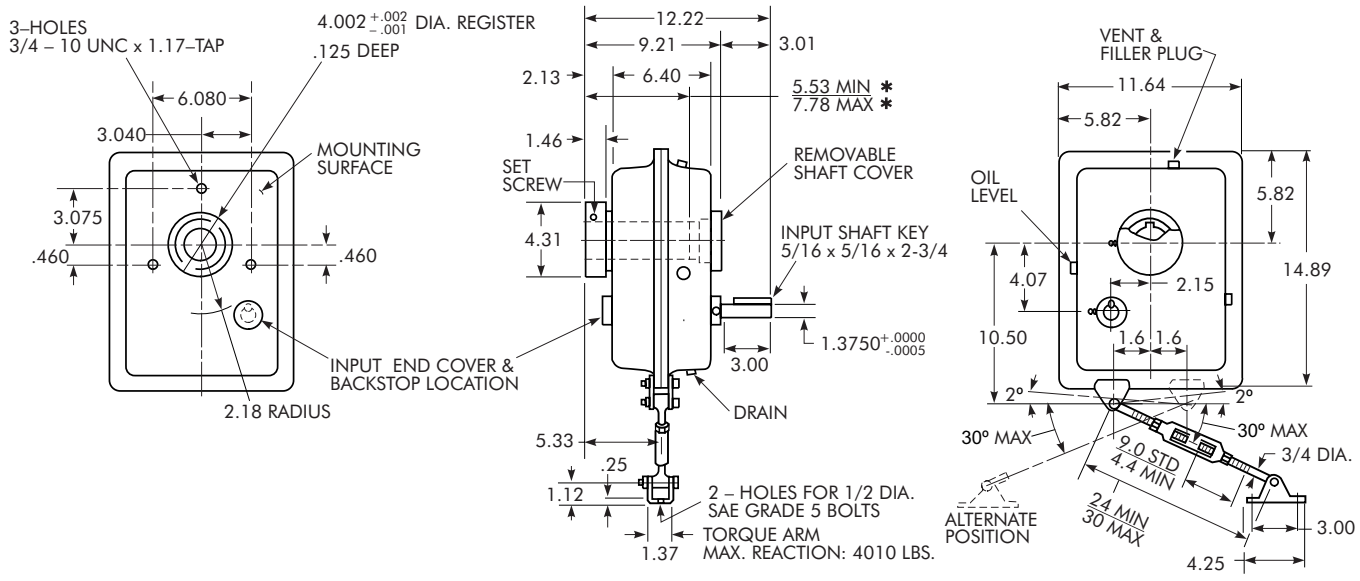

Hollow Shaft Details

See Manual 377-140 for JF drive tapered driven shaft recommendations. See Manual 377-142 for JF drives using tapered bushings.

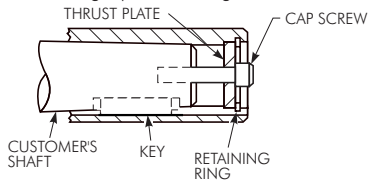

Angular Limits For Horizontal Mounting

(All Clock Positions)
 Refer to Factory for lubrication analysis of all inclined drives exceeding the maximum specified below. Also for drives with combined incline down and rotation.

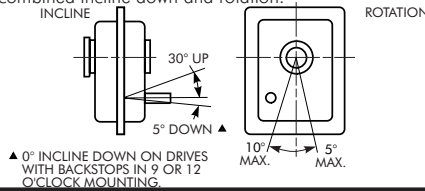

BASIC DRIVE SIZE †	Part Number	Exact Ratio	Max Output rpm	Wt lb
5203J05A	0794374	5.071	350	110
5203J09A	0794375	9.179	190	115
5203J14A	0794376	14.452	125	115
5203J25A	0794377	26.942	70	115

* † (See footnotes on Page 16.)

TA Taper Bushings

Style No. 1 — Thin-wall bushing

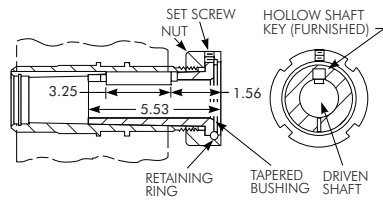

Style No. 2 — Thick-wall bushing

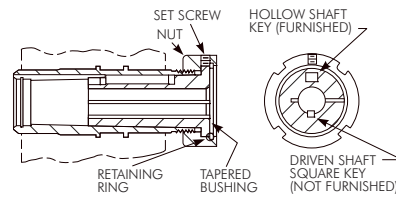

BUSHING SIZE	Part Number †	Style No.	Driven Shaft Keyway/Min Key Length •	Wt lb
BU5203J-1.438	0769117	2	3/8 x 3/16 x 3/4	5.0
BU5203J-1.500	0769118	2	3/8 x 3/16 x 3/4	5.1
BU5203J-1.625	0769119	2	3/8 x 3/16 x 3	4.6
BU5203J-1.688	0769120	2	3/8 x 3/16 x 2 3/4	4.4
BU5203J-1.750	0769121	2	1/2 x 1/4 x 2 3/4	4.4
BU5203J-1.875	0769122	1	1/2 x 1/4 x 3 1/4	3.6
BU5203J-1.938	0769123	1	1/2 x 1/4 x 3 1/4	3.3
BU5203J-2.000	0769124	1	1/2 x 1/4 x 3 1/4	3.0
BU5203J-2.188	0769125	1	1/2 x 1/4 x 3 1/4	3.0

† • (See footnotes on Page 16.)

Accessories

Torque Arm

TA5203J
 PN 0785263
 Wt. 6 lb.

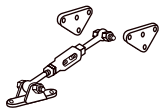

Backstop

BS5203J05/09/14/25
 PN 0785596
 Wt. 1 lb.



Thrust Plate Kit

TP5203J
 PN 0769116
 Wt. 1 lb.



Vertical Breather

VB5203J-HSS Up
 PN 0738540
 VB5203J-HSS Down
 PN 0738541
 Wt. 5 lb.



Vertical Drives

Refer to Factory for lubrication analysis of all vertical drives exceeding ±1° from true vertical.

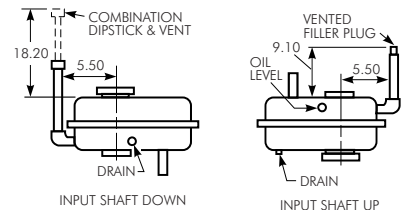

Size 5203/Dimensions – Inches

Screw Conveyor (JSC) Drive ★

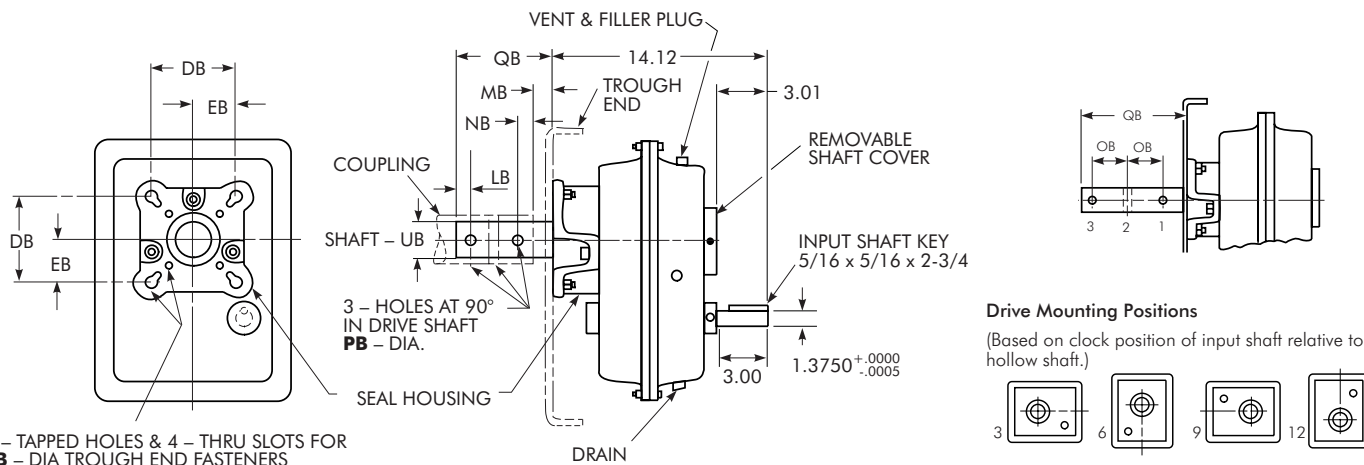

4 – TAPPED HOLES & 4 – THRU SLOTS FOR
FB – DIA TROUGH END FASTENERS

BASIC DRIVE SIZE ★	Screw Conveyor Components										DB	EB	FB ▲	LB	MB	NB	OB	PB	QB	UB †
	Cplg Dia	Screw Dia	Max Tq lb-in	Drive Shaft w/Thrust Plate ‡	Part No.	Wt lb	Seal Housing	Part No.	Wt lb											
5203	1.500	6, 9	5,200	DS5203J-1.500 *	6720016	16	SH5203J	0769114	15	4.000	2.000	.500	3.875	1.250	.875	3.000	.531	9.000 *	1.500	
	2.000	9, 12	10,200	DS5203J-2.000 *	6720017	20	SH5203J	0769114	15	5.125	2.562	.625	3.875	1.250	.875	3.000	.656	9.000 *	2.000	
	2.437	12, 14	11,600	DS5203J-2.437	6720018	21	SH5203J	0769114	15	5.625	2.812	.625	.938	1.812	.938	3.000	.656	6.688	2.437	
	3.000	12-20	11,600	DS5203J-3.000	6720019	26	SH5203J	0769114	15	6.000	3.000	.750	1.000	1.875	1.000	3.000	.781	6.875	3.000	

★ ▲ † ‡ (See footnotes on Page 17.)
* (See footnote on Page 19.)

Trough End Seals

Waste Packing

Std.-Included
with seal housing
PN 0925058
Wt. 1 lb.

Lip Seal
PN 2911847
Wt. 1 lb.

Packing Gland Seal Kit

PGSK5203J
PN 0769115
Wt. 1 lb.

Packing Gland Seal (Only)

PG5203J
PN 1184314
Wt. 1 lb.

Motor Mounts

Standard Horizontal Drive Assembly – (6 o'clock) ♦ (3-9-12 o'clock optional)

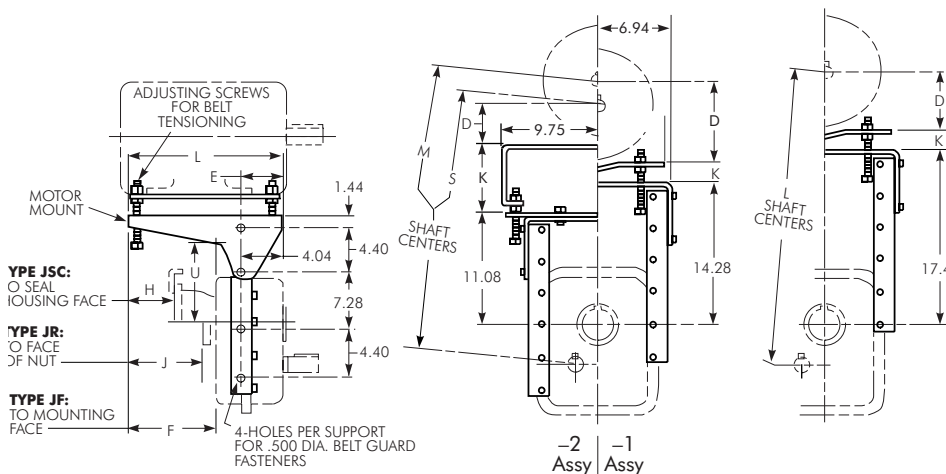

Frame	56	143-145T	182-184T	213-215T
D	3.50	3.50	4.50	5.25
E	2.50	2.00	2.50	3.25
Shaft Centers	Min-Max	Min-Max	Min-Max	Min-Max
(S) Short	19.4-22.7	19.4-22.7	20.4-23.7	21.2-24.4
(M) Medium	22.6-25.9	22.6-25.9	23.6-26.9	24.3-27.6
(L) Long	25.8-29.1	25.8-29.1	26.8-30.1	27.5-30.8
Frame	254-256T	284-286T		
D	6.25	7.00		
E	4.57	4.44		
Shaft Centers	Min-Max	Min-Max		
(S) Short	26.7-30.3	27.4-31.0		
(M) Medium	29.9-33.5	30.6-34.2		
(L) Long	33.1-36.7	33.8-37.4♣		

♣ At 6 o'clock only.

MOTOR MOUNT SIZE ●	Part Number	Type T Frame ■		F	H	J	K		L	U			Motor Mount Wt-lb
		Min	Max				Min	Max		Short	Med	Long	
MM5203J-1	0738716	56	215	8.36	4.36	6.23	0.64	3.92	15.00	7.94	11.14	14.34	47
MM5203J-2	0786108	254	286	13.74	9.74	11.62	5.20	8.78	21.00	7.94	11.14	14.34	90

● ■ ♦ (See footnotes on Page 17.)

Size 5207/Dimensions – Inches

Shaft Mounted (JR) & Flange Mounted (JF) Drive ★

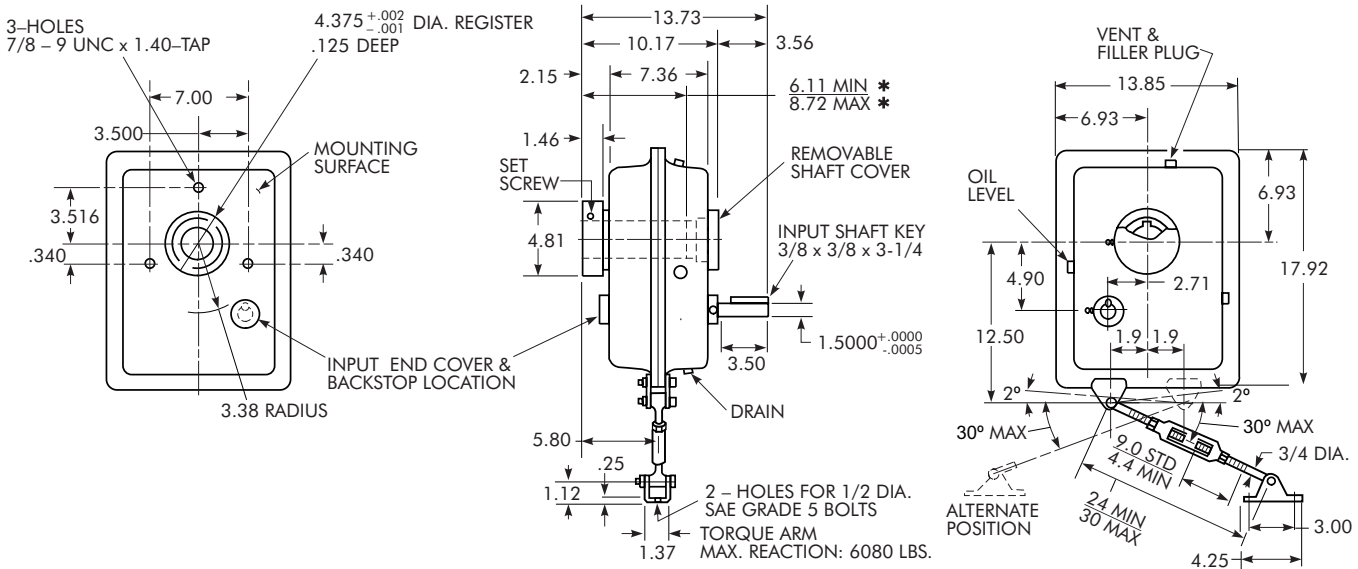

Hollow Shaft Details

See Manual 377-140 for JF drive tapered driven shaft recommendations. See Manual 377-142 for JF drives using tapered bushings.

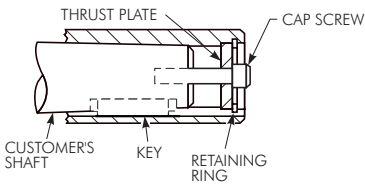

Angular Limits For Horizontal Mounting

(All Clock Positions)
 Refer to Factory for lubrication analysis of all inclined drives exceeding the maximum specified below. Also for drives with combined incline down and rotation.

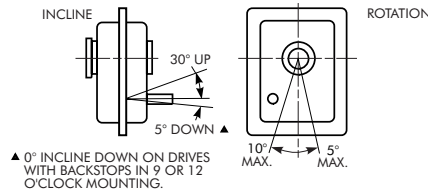

BASIC DRIVE SIZE †	Part Number	Exact Ratio	Max Output rpm	Wt lb
5207J05A	0794378	5.077	350	180
5207J09A	0794379	9.492	190	190
5207J14A	0794380	14.47	125	190
5207J25A	0794381	24.99	70	190

* † (See footnotes on Page 16.)

TA Taper Bushings

Style No. 1 — Thin-wall bushing

Style No. 2 — Thick-wall bushing

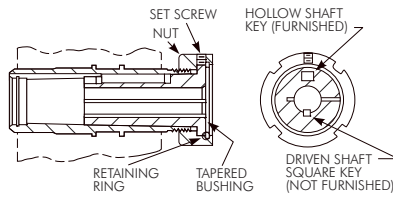
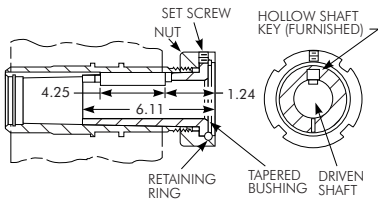

BUSHING SIZE	Part Number ‡	Style No.	Driven Shaft Keyway/Min Key Length •	Wt lb
BU5207J-1.375	0769095	2	3/16 x 5/32 x 5 1/4	7.6
BU5207J-1.438	0769096	2	3/8 x 3/16 x 5 3/4	7.3
BU5207J-1.500	0769097	2	3/8 x 3/16 x 5 3/4	7.1
BU5207J-1.625	0765848	2	3/8 x 3/16 x 5 3/4	6.7
BU5207J-1.688	0769098	2	3/8 x 3/16 x 5 1/4	6.4
BU5207J-1.750	0769099	2	3/8 x 3/16 x 5 1/4	6.1
BU5207J-1.875	0769100	2	1/2 x 1/4 x 3 1/2	5.6
BU5207J-1.938	0769101	1	1/2 x 1/4 x 4 1/4	5.3
BU5207J-2.000	0769102	1	1/2 x 1/4 x 4 1/4	5.0
BU5207J-2.188	0769103	1	1/2 x 1/4 x 4 1/4	4.4
BU5207J-2.250	0769104	1	1/2 x 1/4 x 4 1/4	3.7
BU5207J-2.375	2113886	1	5/8 x 5/16 x 4 1/4	3.0
BU5207J-2.438	0769105	1	5/8 x 5/16 x 4 1/4	2.6

‡ • (See footnotes on Page 16.)

Accessories

Torque Arm

TA5207J
 PN 0785265
 Wt. 7 lb.

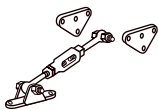

Backstop

BS5207J05/09/14/25
 PN 0783905
 Wt. 2 lb.



Thrust Plate Kit

TP5207J
 PN 0769094
 Wt. 1 lb.



Vertical Breather

VB5207J-HSS Up
 PN 0738569
 VB5207J-HSS Down
 PN 0738570
 Wt. 6 lb.



Vertical Drives

Refer to Factory for lubrication analysis of all vertical drives exceeding ± 1° from true vertical.

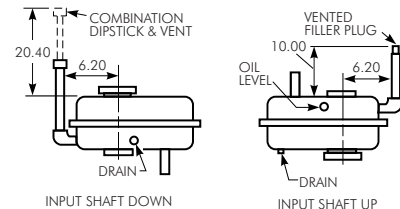

Size 5215/Dimensions – Inches

Shaft Mounted (JR) & Flange Mounted (JF) Drive ★

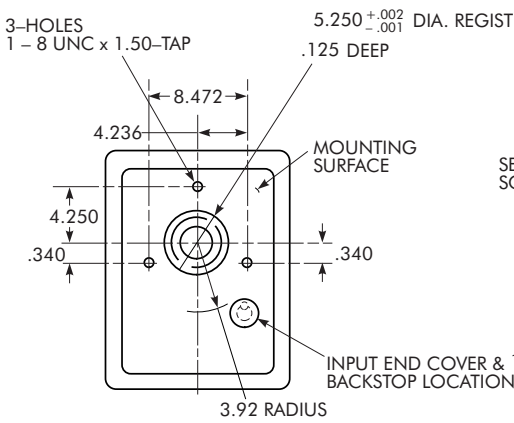

Shaft Fan Kit

SFK5215J
PN 0785611
Wt. 4 lb.

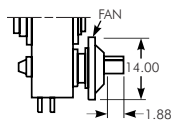

Hollow Shaft Details

See Manual 377-140 for JF drive tapered driven shaft recommendations. See Manual 377-142 for JF drives using tapered bushings.

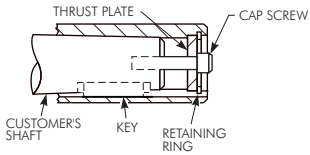

Angular Limits For horizontal Mounting

(All Clock Positions)
Refer to Factory for lubrication analysis of all inclined drives exceeding the maximum specified below. Also for drives with combined incline down and rotation.

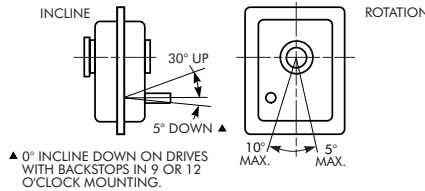

▲ 0° INCLINE DOWN ON DRIVES WITH BACKSTOPS IN 9 OR 12 O'CLOCK MOUNTING.

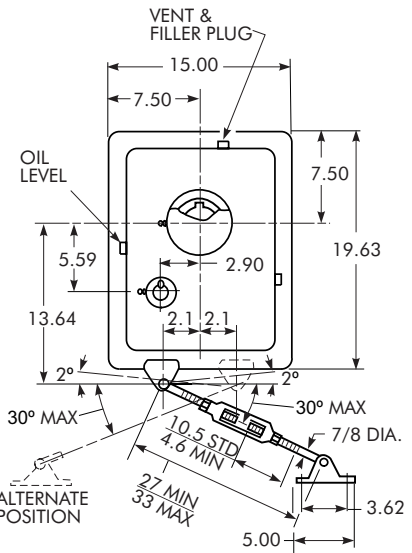
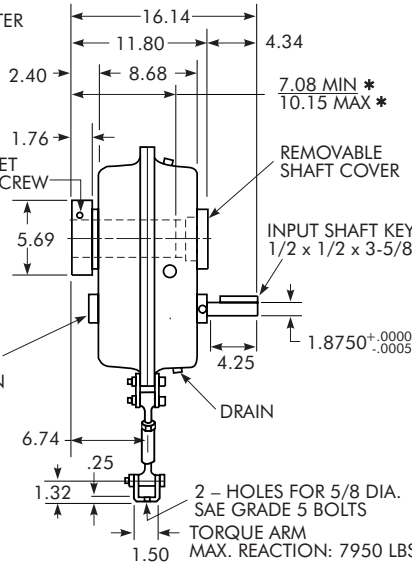

BASIC DRIVE SIZE †	Part Number	Exact Ratio	Max Output rpm	Wt lb
5215J05A	0794382	4.923	350	245
5215J09A	0794383	8.997	190	260
5215J14A	0794384	13.60	125	260
5215J25A	0794385	24.94	70	260

* † (See footnotes on Page 16.)

TA Taper Bushings

Style No. 1 — Thin-wall bushing

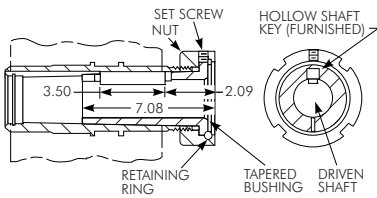

Style No. 2 — Thick-wall bushing

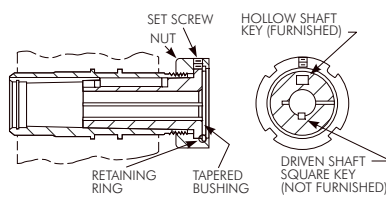

BUSHING SIZE	Part Number †	Style No.	Driven Shaft Keyway/Min Key Length •	Wt lb
BU5215J-1.938	0769137	2	1/2 x 1/4 x 5	11.4
BU5215J-2.000	0769138	2	1/2 x 1/4 x 4 1/2	11.1
BU5215J-2.188	0769139	2	1/2 x 1/4 x 4 1/4	9.9
BU5215J-2.250	0769140	2	1/2 x 1/4 x 4 1/4	9.5
BU5215J-2.438	0769141	1	5/8 x 3/16 x 3 1/2	8.3
BU5215J-2.500	0769142	1	5/8 x 3/16 x 3 1/2	7.8
BU5215J-2.688	0769143	1	5/8 x 3/16 x 3 1/2	6.5
BU5215J-2.750	2116065	1	5/8 x 3/16 x 3 1/2	5.5
BU5215J-2.938	0769144	1	3/4 x 3/8 x 3 1/2	4.5

† • (See footnotes on Page 16.)

Accessories

Torque Arm

TA5215J
PN 0785267
Wt. 10 lb.

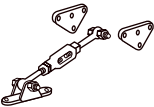

Backstop

BS5215J05/09/14/25
PN 0785610
Wt. 3 lb.



Thrust Plate Kit

TP5215J
PN 0769136
Wt. 2 lb.



Vertical Breather

VB5215J-HSS Up
PN 0786774
VB5215J-HSS Down
PN 0738577
Wt. 6 lb.



Vertical Drives

Refer to Factory for lubrication analysis of all vertical drives exceeding ±1° from true vertical.

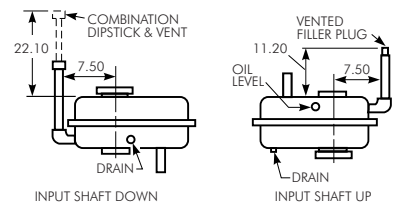

Size 5215/Dimensions – Inches

Screw Conveyor (JSC) Drive ★

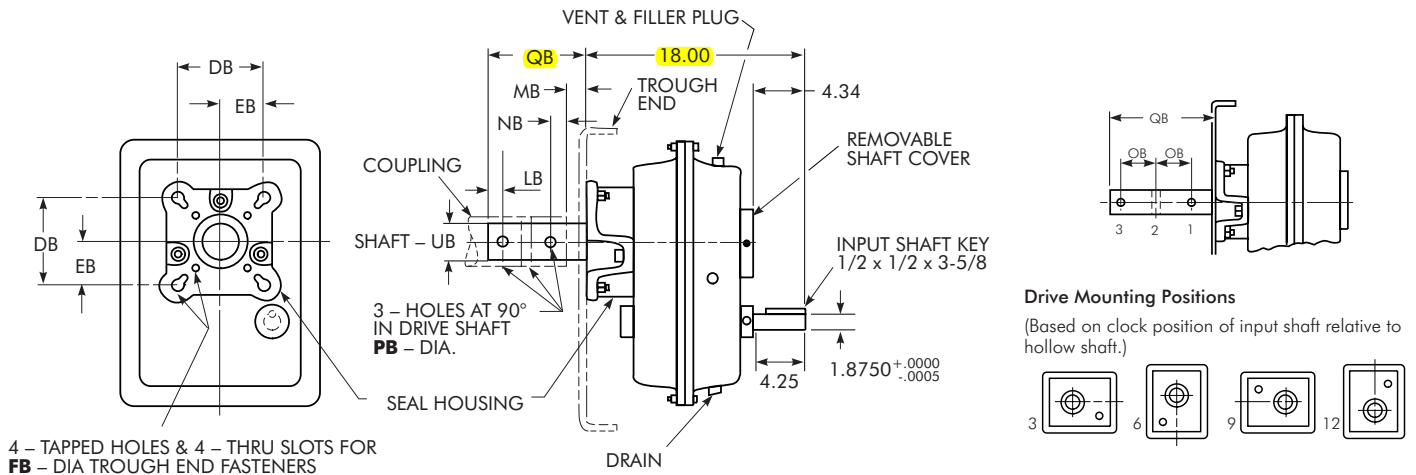

BASIC DRIVE SIZE ★	Screw Conveyor Components										DB	EB	FB ▲	LB	MB	NB	OB	PB	QB	UB †
	Cplg Dia	Screw Dia	Max Tq lb-in	Drive Shaft w/Thrust Plate ‡	Part No.	Wt lb	Seal Housing	Part No.	Wt lb											
5215	2.000	9, 12	12,200	DS5215J-2.000 *	6720025	34	SH5215J	0769134	23	5.125	2.562	.625	3.875	1.250	.875	3.000	.656	9.000 *	2.000	
	2.437	12, 14	18,200	DS5215J-2.437 *	6720026	39	SH5215J	0769134	23	5.625	2.812	.625	3.938	1.812	.938	3.000	.656	9.688 *	2.437	
	3.000	12-20	24,800	DS5215J-3.000 *	6720027	46	SH5215J	0769134	23	6.000	3.000	.750	4.000	1.875	1.000	3.000	.781	9.875 *	3.000	
	3.437	18-24	31,900	DS5215J-3.437	6720028	50	SH4215J	0769134	23	6.750	3.375	.750	1.250	2.375	1.500	4.000	.906	9.125	3.437	

★ ▲ † ‡ (See footnotes on Page 17.)
 * (See footnote on Page 19.)

Trough End Seals

Waste Packing Std.-Included with seal housing PN 0925058 Wt. 1 lb.	Lip Seal PN 2911957 Wt. 1 lb.	Packing Gland Seal Kit PGSK5215J PN 0769135 Wt. 1 lb.	Packing Gland Seal (Only) PG5215J PN 1231045 Wt. 1 lb.
--	-------------------------------------	--	---

Motor Mounts

Standard Horizontal Drive Assembly – (6 o'clock) ♦ (3-9-12 o'clock optional)

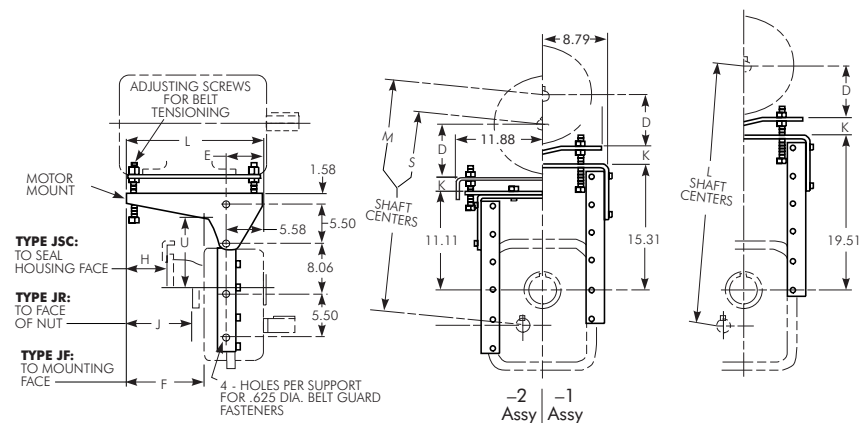

Frame ♣	56	143-145T	182-184T	213-215T
D	3.50	3.50	4.50	5.25
E	2.50	2.00	2.50	3.25
Shaft Centers	Min-Max	Min-Max	Min-Max	Min-Max
(S) Short	21.0-24.3	21.0-24.3	22.0-25.3	22.8-26.0
(M) Medium	25.2-28.5	25.2-28.5	26.2-29.5	26.9-30.2
(L) Long	29.4-32.7	29.4-32.7	30.4-33.7	31.1-34.4
Frame	254-256T	284-286T	324-326T	364-365T
D	6.25	7.00	8.00	9.00
E	3.94	4.44	4.94	5.57
Shaft Centers	Min-Max	Min-Max	Min-Max	Min-Max
(S) Short	24.8-28.9	25.5-29.6	26.5-30.6	27.5-31.6
(M) Medium	28.9-33.0	29.7-33.8	30.7-34.8	31.7-35.8
(L) Long	33.1-37.2	33.9-38.0	34.9-39.0	35.9-40.0 ♠

♠ At 6 o'clock only.

MOTOR MOUNT SIZE ●	Part Number	Type T Frame ■		F	H	J	K		L	U			Motor Mount Wt.-lb
		Min	Max				Min	Max		Short	Med	Long	
MM5215J-1	0738720	56	215	6.06	1.80	3.66	0.64	3.92	15.00	8.40	12.60	16.80	62
MM5215J-2	0786261	254	365	16.42	12.17	14.00	1.50	5.75	26.00	8.40	12.60	16.80	125

● ■ ♦ (See footnotes on Page 17.)
 ♣ Shaft driven fans are not compatible with motor mounts for frames 56 thru 215T.

Size 5307/Dimensions – Inches

Shaft Mounted (JR) & Flange Mounted (JF) Drive ★

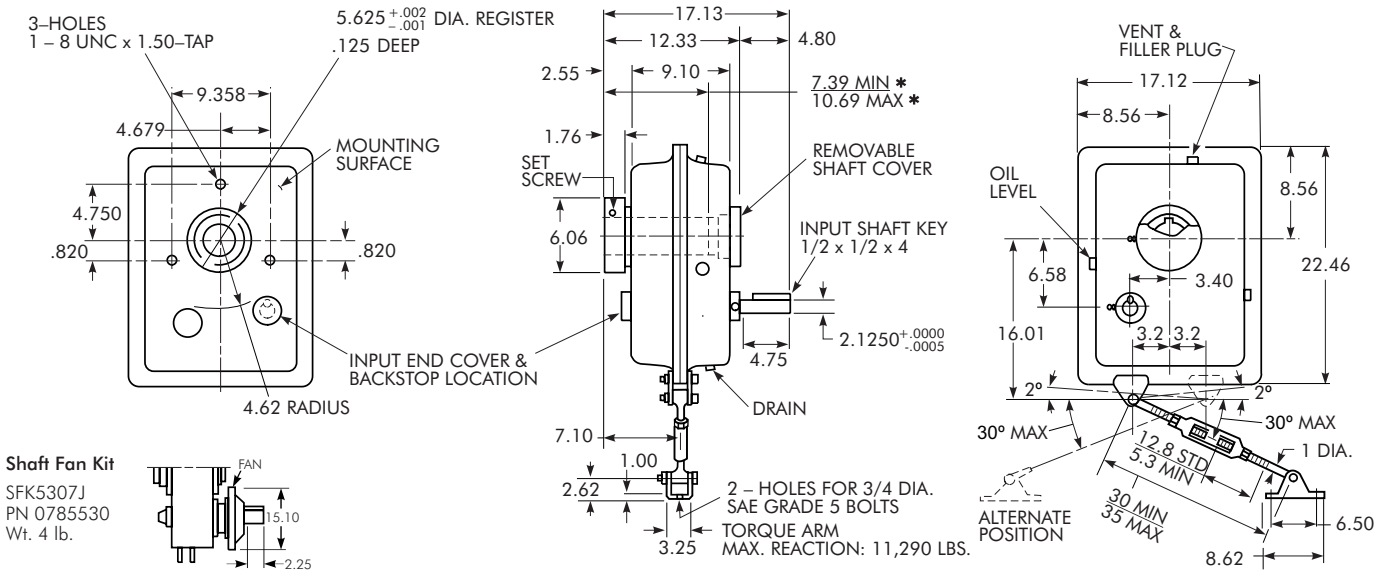

Shaft Fan Kit

SFK5307J
PN 0785530
Wt. 4 lb.

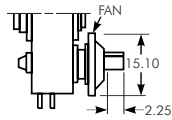

Hollow Shaft Details

See Manual 377-140 for JF drive tapered driven shaft recommendations. See Manual 377-142 for JF drives using tapered bushings.

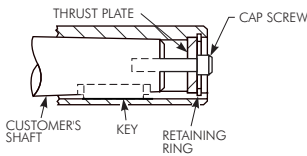

Angular Limits For Horizontal Mounting

(All Clock Positions)

Refer to Factory for lubrication analysis of all inclined drives exceeding the maximum specified below. Also for drives with combined incline down and rotation.

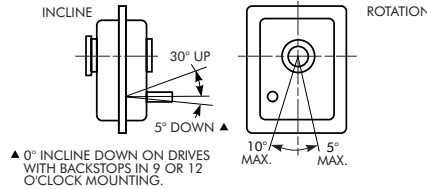

BASIC DRIVE SIZE †	Part Number	Exact Ratio	Max Output rpm	Wt lb
5307J05A	0794386	4.857	350	355
5307J09A	0794387	9.131	190	375
5307J14A	0794388	14.03	125	375
5307J25A	0794389	25.26	70	375

* † (See footnotes on Page 16.)

TA Taper Bushings

Style No. 1 — Thin-wall bushing

Style No. 2 — Thick-wall bushing

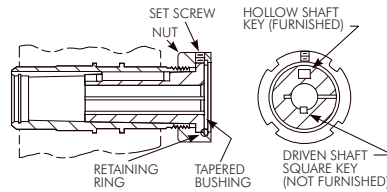
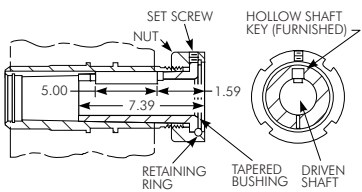

BUSHING SIZE	Part Number ‡	Style No.	Driven Shaft Keyway/Min Key Length •	Wt lb
BU5307J-2.000	0769155	2	1/2 x 1/4 x 7	17.8
BU5307J-2.188	0769156	2	1/2 x 1/4 x 7	16.6
BU5307J-2.250	0769157	2	1/2 x 1/4 x 7	16.2
BU5307J-2.438	0769158	2	5/8 x 5/16 x 5 1/2	14.9
BU5307J-2.500	0769159	2	5/8 x 5/16 x 5	14.4
BU5307J-2.688	0769160	1	5/8 x 5/16 x 5	13.0
BU5307J-2.938	0769161	1	3/4 x 3/8 x 5	10.9
BU5307J-3.000	0769162	1	3/4 x 3/8 x 5	10.3
BU5307J-3.188	0769163	1	3/4 x 3/8 x 5	8.6
BU5307J-3.438	0769164	1	7/8 x 7/16 x 5	6.1

‡ • (See footnotes on Page 16.)

Accessories

Torque Arm

TA5307J
PN 0785269
Wt. 25 lb.

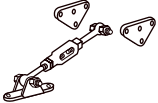

Backstop ■

BS5307J09/14/25
PN 0785529
Wt. 3 lb.

■ Not available in 5:1 ratio.



Thrust Plate Kit

TP53075J
PN 0769154
Wt. 3 lb.



Vertical Breather

VB5307J-HSS Up
PN 0786774
VB5307J-HSS Down
PN 0738470
Wt. 7 lb.

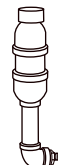

Vertical Drives

Refer to Factory for lubrication analysis of all vertical drives exceeding ±1° from true vertical.

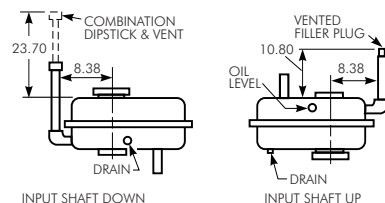

Size 5307/Dimensions – Inches

Screw Conveyor (JSC) Drive ★

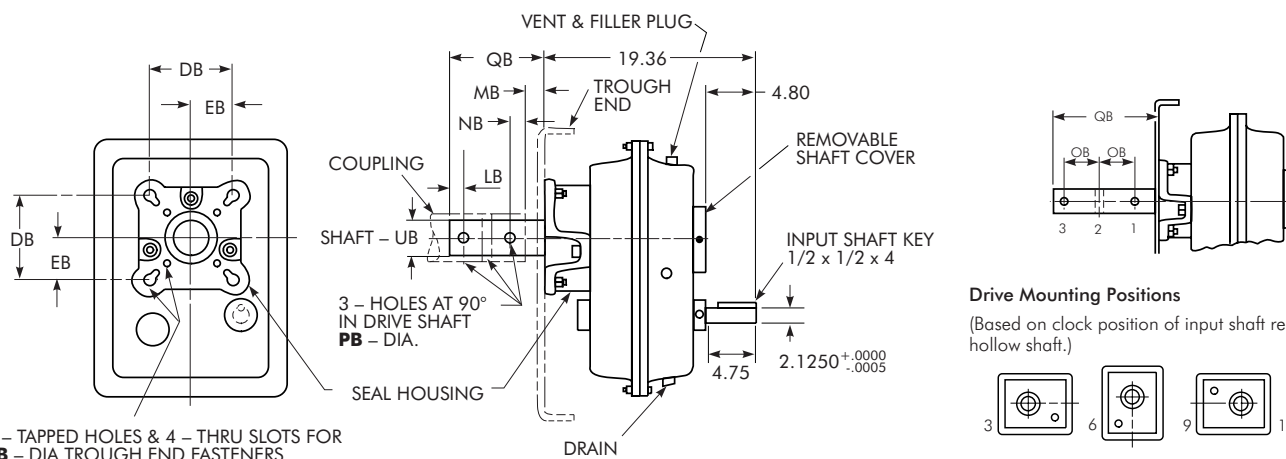

4 - TAPPED HOLES & 4 - THRU SLOTS FOR FB - DIA TROUGH END FASTENERS

Drive Mounting Positions

(Based on clock position of input shaft relative to hollow shaft.)

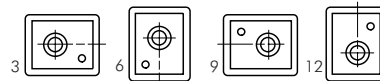

BASIC DRIVE SIZE ★	Screw Conveyor Components										DB	EB	FB ▲	LB	MB	NB	OB	PB	QB	UB †
	Cplg Dia	Screw Dia	Max Tq lb-in	Drive Shaft w/Thrust Plate ‡	Part No.	Wt lb	Seal Housing	Part No.	Wt lb											
5307	2.437	12, 14	18,200	DS5307J-2.437 *	6720029	49	SH5307J	0769152	36	5.625	2.812	.625	3.938	1.812	.938	3.000	.656	9.688 *	2.437	
	3.000	12-20	34,300	DS5307J-3.000 *	6720030	56	SH5307J	0769152	36	6.000	3.000	.750	4.000	1.875	1.000	3.000	.781	9.875 *	3.000	
	3.437	18-24	51,400	DS5307J-3.437 *	6720031	70	SH5307J	0769152	36	6.750	3.375	.750	5.250	2.375	1.500	4.000	.906	13.125 *	3.437	

★ ▲ † ‡ (See footnotes on Page 17.)

* (See footnote on Page 19.)

Trough End Seals

Waste Packing

Std.-Included with seal housing
PN 0925058
Wt. 1 lb.

Lip Seal

PN 0912741
Wt. 1 lb.

Packing Gland Seal Kit

PGSK5307J
PN 0738466
Wt. 1 lb.

Packing Gland Seal (Only)

PG5307J
PN 1184315
Wt. 1 lb.

Motor Mounts

Standard Horizontal Drive Assembly – (6 o'clock) ♦ (3-9-12 o'clock optional)

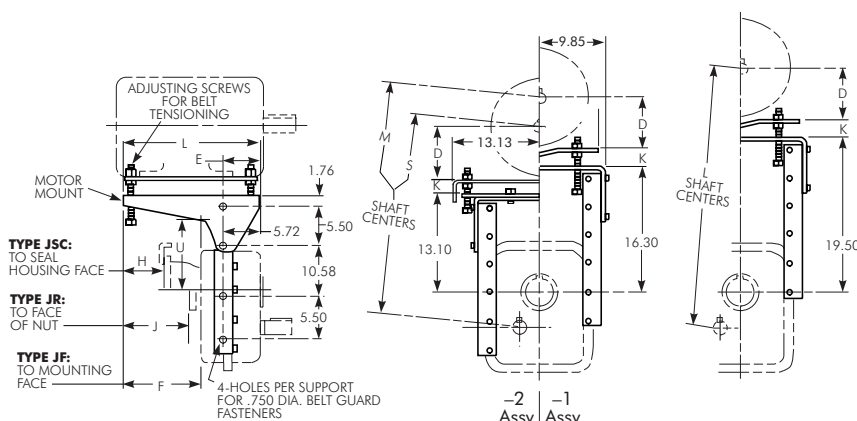

MOTOR MOUNT SIZE ●	Part Number	Type T Frame ■		F	H	J	K		L	U			Motor Mount Wt.-lb
		Min	Max				Min	Max		Short	Med	Long	
MM5307J-1	0738468	56	215	5.64	0.88	3.09	0.64	3.92	15.00	10.30	13.50	16.70	67
MM5307J-2	0786373	254	404	16.00	11.26	13.46	1.50	5.75	25.50	10.30	13.50	16.70	140

● ■ ♦ (See footnotes on Page 17.)

♣ (See footnote on Page 25.)

Frame ♣	56	143-145T	182-184T	213-215T
D	3.50	3.50	4.50	5.25
E	2.50	2.00	2.50	3.25
Shaft Centers	Min-Max	Min-Max	Min-Max	Min-Max
(S) Short	24.1-27.3	24.1-27.3	25.0-28.3	25.8-29.0
(M) Medium	27.2-30.5	27.2-30.5	28.2-31.5	29.0-32.2
(L) Long	30.4-33.7	30.4-33.7	31.4-34.7	32.1-35.4
Frame	254-256T	284-286T	324-326T	364-365T
D	6.25	7.00	8.00	9.00
E	3.43	3.93	4.43	5.06
Shaft Centers	Min-Max	Min-Max	Min-Max	Min-Max
(S) Short	27.8-31.9	28.5-32.6	29.5-33.6	30.5-34.6
(M) Medium	31.0-35.0	31.7-35.8	32.7-36.8	33.7-37.8
(L) Long	34.1-38.2	34.9-39.0	35.9-40.0	36.9-41.0
Frame	404T			
D	10.00			
E	5.81			
Shaft Centers	Min-Max			
(S) Short	31.5-35.6			
(M) Medium	34.7-38.8			
(L) Long	37.9-42.0			

Size 5315/Dimensions – Inches

Shaft Mounted (JR) & Flange Mounted (JF) Drive ★

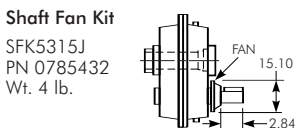
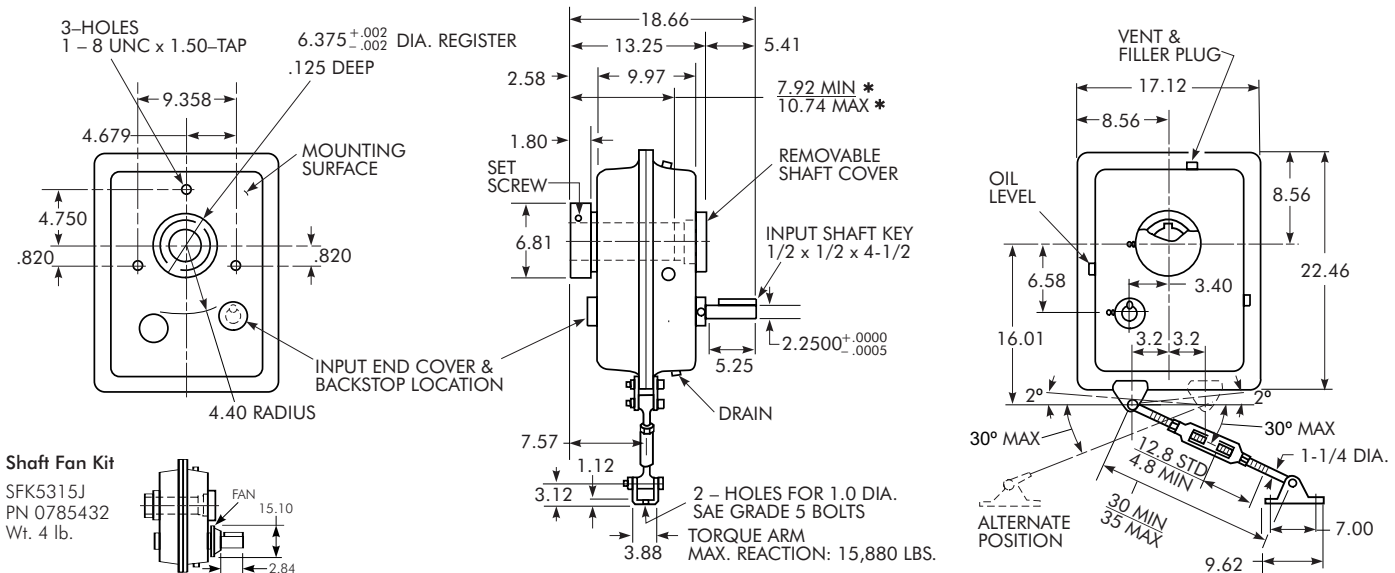

Hollow Shaft Details
See Manual 377-140 for JF drive tapered driven shaft recommendations. See Manual 377-142 for JF drives using tapered bushings.

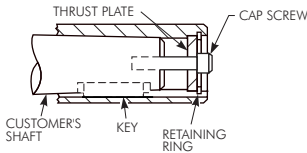

Angular Limits For Horizontal Mounting
(All Clock Positions)
Refer to Factory for lubrication analysis of all inclined drives exceeding the maximum specified below. Also for drives with combined incline down and rotation.

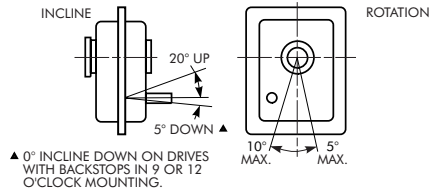

BASIC DRIVE SIZE †	Part Number	Exact Ratio	Max Output rpm	Wt lb
5315J05A	0794390	4.857	350	375
5315J09A	0794391	9.131	190	400
5315J14A	0794392	13.91	125	400
5315J25A	0794393	25.26	70	400

* † (See footnotes on Page 16.)

TA Taper Bushings

Style No. 1 — Thin-wall bushing

Style No. 2 — Thick-wall bushing

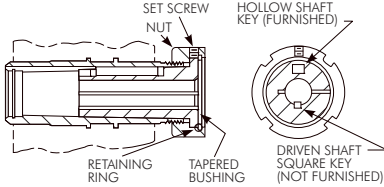
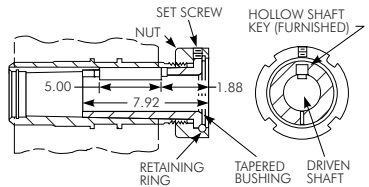

BUSHING SIZE	Part Number †	Style No.	Driven Shaft Keyway/Min Key Length •	Wt lb
BU5315J-2.438	0785778	2	3/8 x 3/16 x 7 1/2	23.6
BU5315J-2.500	0785779	2	5/8 x 5/16 x 7 1/2	23.1
BU5315J-2.688	0785780	2	3/8 x 3/16 x 7 1/2	21.6
BU5315J-2.938	0785781	2	3/4 x 3/8 x 5 1/2	19.4
BU5315J-3.000	0785782	2	3/4 x 3/8 x 5 1/2	18.8
BU5315J-3.438	0785783	1	7/8 x 7/16 x 5	14.3
BU5315J-3.938	0785784	1	1 x 1/2 x 5	8.4

† • (See footnotes on Page 16.)

Accessories

Torque Arm
TA5315J
PN 0785270
Wt. 38 lb.

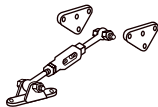

Backstop ■
BS5315J09/14/25
PN 0757183
Wt. 7 lb.
■ Not available in 5:1 ratio.



Thrust Plate Kit
TP5315J
PN 0769207
Wt. 4 lb.



Vertical Breather
VB5315J-HSS Up
PN 0738471
VB5315J-HSS Down
PN 0738470
Wt. 7 lb.



Vertical Drives
Refer to Factory for lubrication analysis of all vertical drives exceeding ±1° from true vertical.

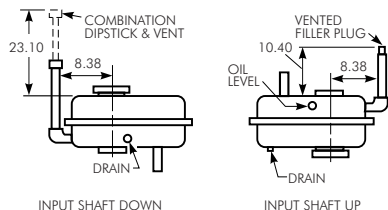

Size 5315/Dimension – Inches

Screw Conveyor (JSC) Drive ★

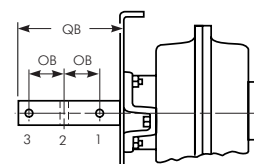
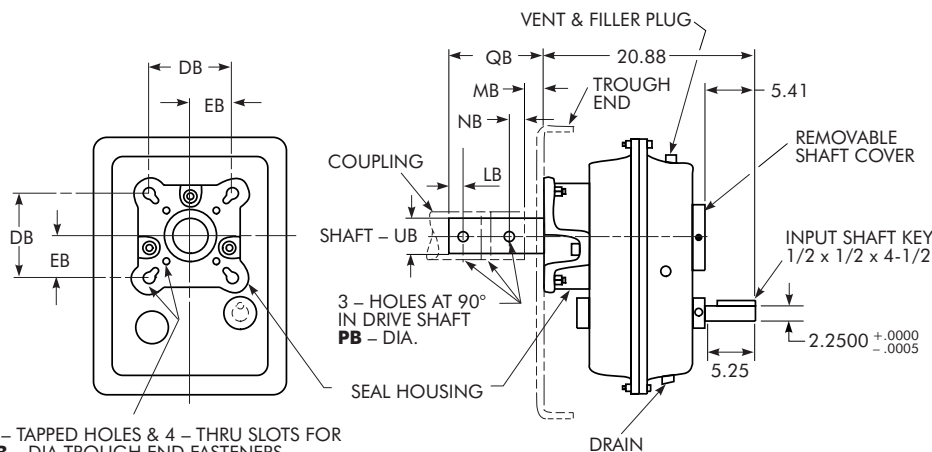

Drive Mounting Positions

(Based on clock position of input shaft relative to hollow shaft.)



4 – TAPPED HOLES & 4 – THRU SLOTS FOR FB – DIA TROUGH END FASTENERS

BASIC DRIVE SIZE ★	Screw Conveyor Components									DB	EB	FB ▲	LB	MB	NB	OB	PB	QB	UB †
	Cplg Dia	Screw Dia	Max Tq lb-in	Drive Shaft w/Thrust Plate ‡	Part No.	Wt lb	Seal Housing	Part No.	Wt lb										
5315	2.437	12, 14	18,220	D55315J-2.437 *	6720032	58	SH5315J	0769206	36	5.625	2.812	.625	3.938	1.812	.938	3.000	.656	9.688 *	2.437
	3.000	12-20	34,300	D55315J-3.000 *	6720033	65	SH5315J	0769206	36	6.000	3.000	.750	4.000	1.875	1.000	3.000	.781	9.875 *	3.000
	3.438	18-24	51,400	D55315J-3.437 *	6720034	80	SH5315J	0769206	36	6.750	3.375	.750	5.250	2.375	1.500	4.000	.906	13.125 *	3.437

★ ▲ † ‡ (See footnotes on Page 17.)
* (See footnote on Page 19.)

Trough End Seals

Waste Packing

Std.-Included with seal housing
PN 0925058
Wt. 1 lb.

Lip Seal

PN 0912741
Wt. 1 lb.

Packing Gland Seal Kit

PGSK5315J
PN 0738466
Wt. 1 lb.

Packing Gland Seal (Only)

PG5315J
PN 1184315
Wt. 1 lb.

Motor Mounts

Standard Horizontal Drive Assembly – (6 o'clock) ♦ (3-9-12 o'clock optional)

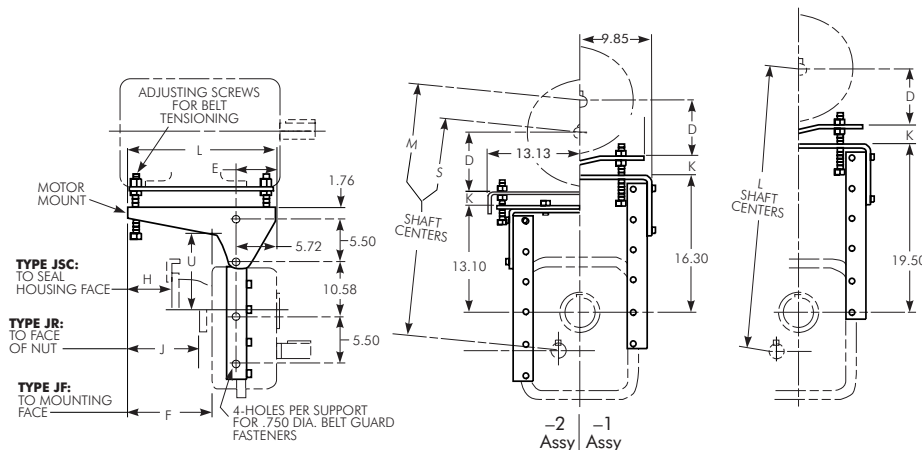

Frame ♣	56	143-145T	182-184T	213-215T
D	3.50	3.50	4.50	5.25
E	2.50	2.00	2.50	3.25
Shaft Centers	Min-Max	Min-Max	Min-Max	Min-Max
(S) Short	24.1-27.3	24.1-27.3	25.0-28.3	25.8-29.0
(M) Medium	27.2-30.5	27.2-30.5	28.2-31.5	29.0-32.2
(L) Long	30.4-33.7	30.4-33.7	31.4-34.7	32.1-35.4
Frame	254-256T	284-286T	324-326T	364-365T
D	6.25	7.00	8.00	9.00
E	3.43	3.93	4.43	5.06
Shaft Centers	Min-Max	Min-Max	Min-Max	Min-Max
(S) Short	27.8-31.9	28.5-32.6	29.5-33.6	30.5-34.6
(M) Medium	31.0-35.0	31.7-35.8	32.7-36.8	33.7-37.8
(L) Long	34.1-38.2	34.9-39.0	35.9-40.0	36.9-41.0
Frame	404-405T			
D	10.00			
E	5.81			
Shaft Centers	Min-Max			
(S) Short	31.5-35.6			
(M) Medium	34.7-38.8			
(L) Long	37.9-42.0			

MOTOR MOUNT SIZE ●	Part Number	Type T Frame ■		F	H	J	K		L	U			Motor Mount Wt.-lb
		Min	Max				Min	Max		Short	Med	Long	
MMS5315J-1	0738468	56	215	5.20	0.44	2.62	0.64	3.92	15.00	10.92	14.12	17.32	67
MMS5315J-2	0786373	254	405	15.60	10.83	13.00	1.50	5.75	25.50	10.92	14.12	17.32	140

● ■ ♦ (See footnotes on Page 17.)
♣ (See footnote on Page 25.)

Size 5407/Dimensions – Inches

Shaft Mounted (JR) Drive ★

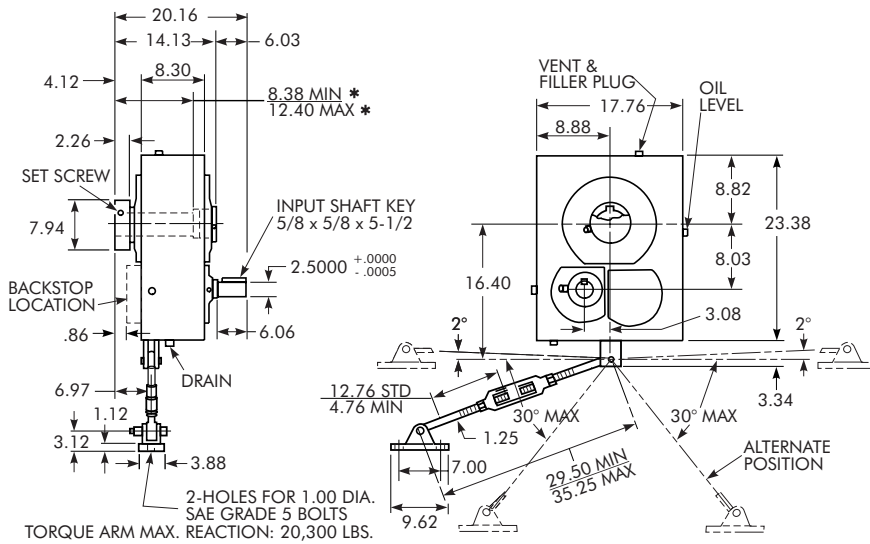

Shaft Fan Kit
 SFK5407J
 PN 0785773
 Wt. 4 lb.

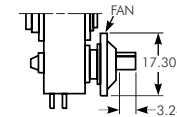

Hollow Shaft Details

See Manual 377-140 for JF drive tapered driven shaft recommendations. See Manual 377-144 for JF drives using tapered bushings.

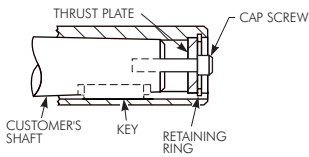

Angular Limits For Horizontal Mounting

(All Clock Positions)

Refer to Factory for lubrication analysis of all inclined drives exceeding the maximum specified below.

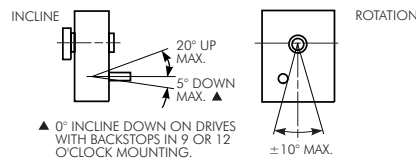

DRIVE SIZE †	Part Number	Exact Ratio	Max Output rpm	Wt lb
5407JR05A	0794695	4.938	350	575
5407JR14A	0794696	13.89	125	606
5407JR25A	0794697	25.04	70	606

★ (See footnote on Page 17.)
 * (See footnote on Page 16.)
 † JR = Drive (Includes Torque Arm) + Bushing.

TA Taper Bushings

Style No. 1 — Thin-wall bushing

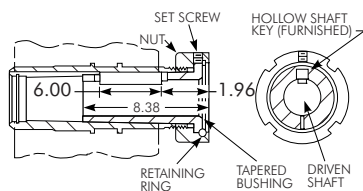

Style No. 2 — Thick-wall bushing

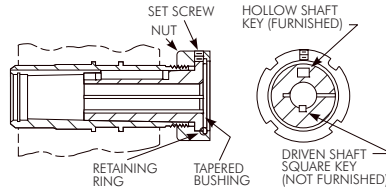

BUSHING SIZE	Part Number ‡	Style No.	Driven Shaft Keyway/Min Key Length •	Wt lb
BU5407J-2.938	0786822	2	3/4 x 3/8 x 7 1/2	29.7
BU5407J-3.438	0785774	1	7/8 x 7/16 x 6	24.0
BU5407J-3.938	0785775	1	1 x 1/2 x 6	17.3
BU5407J-4.188	0785776	1	1 x 1/2 x 6	13.6
BU5407J-4.438	0785777	1	1 x 1/2 x 6	11.4

‡ • (See footnotes on Page 16.)

Size 5407/Dimensions – Inches

Flange Mounted (JF) Drive ★

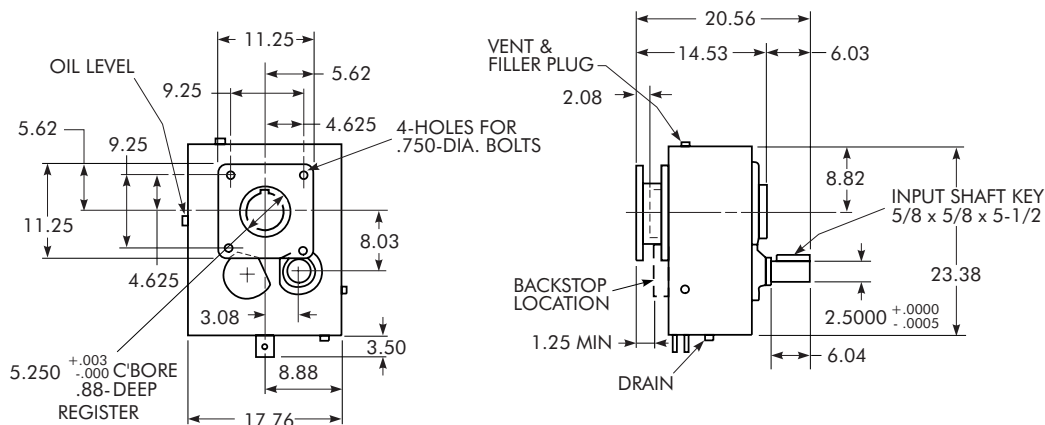

Drive Mounting Positions

(Based on clock position of input shaft relative to hollow shaft.)

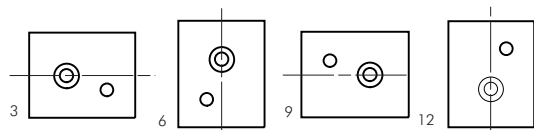

DRIVE SIZE †	Part Number	Exact Ratio	Max Output rpm	Wt lb
5407JF05A	0794394	4.938	350	540
5407JF14A	0794395	13.89	125	610
5407JF25A	0794396	25.04	70	610

† JF = Drive (Includes Output Flange) (Bushing Optional).

Hollow Shaft Details

See Manual 377-140 for JF drive tapered driven shaft recommendations. See Manual 377-144 for JF drives using tapered bushings.

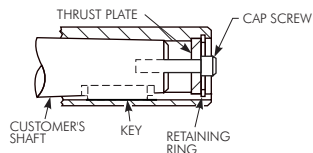

Angular Limits For Horizontal Mounting

(All Clock Positions)

Refer to Factory for lubrication analysis of all inclined drives exceeding the maximum specified below.

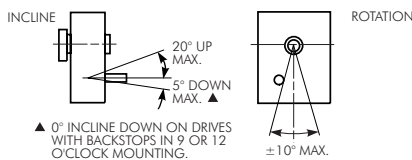

Accessories

Torque Arm

TA5407J
PN 0785271
Wt. 35 lb.

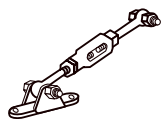

Backstop ■

BS5407J14/25
PN 0769170
Wt. 23 lb.

■ Not available in 5:1 ratio.



Thrust Plate Kit

TP5407J
PN 0769176
Wt. 5 lb.



Vertical Breather

VB5407J-HSS Up W/O Fan
PN 0757208
VB5407J-HSS Down W/O Fan
PN 0757209
VB5407J-HSS Up With Fan
PN 0765839
VB5407J-HSS Down With Fan
PN 0765840
Wt. 7 lb.



Vertical Drives

Refer to Factory for lubrication analysis of all vertical drives exceeding $\pm 1^\circ$ from true vertical.

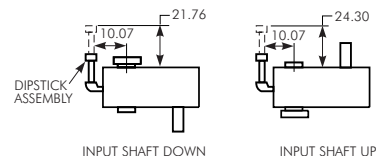

Size 5407/Dimensions – Inches

Screw Conveyor (JSC) Drive ★

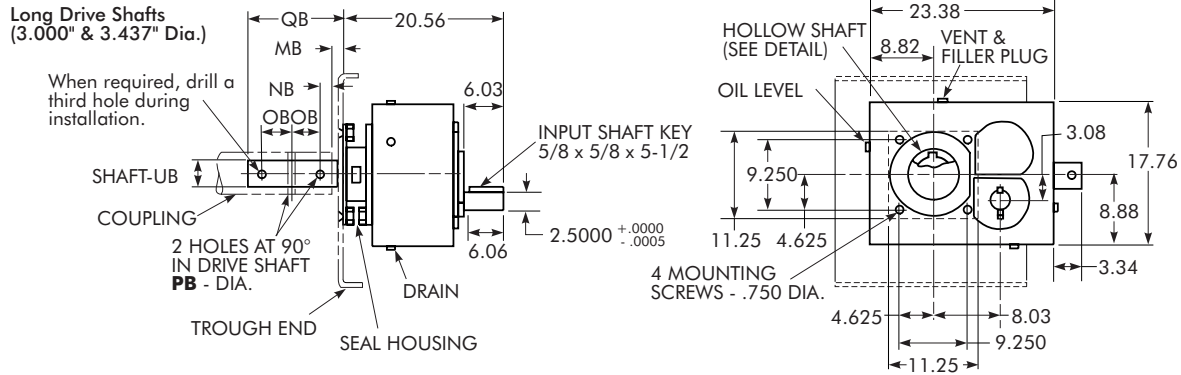

Angular Limits For Horizontal Mounting

(All Clock Positions)

Refer to Factory for lubrication analysis of all inclined drives exceeding the maximum specified below.

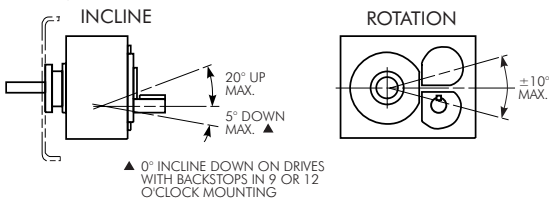

DRIVE SIZE †	Part Number	Exact Ratio	Max Output rpm	Wt lb
5407JSC05A	0794394	4.938	350	540
5407JSC14A	0794395	13.89	125	610
5407JSC25A	0794396	25.04	70	610

† JSC = Drive (Includes Seal Housing) + Drive Shaft + Seal Housing Accessory Kit.

DRIVE SIZE ★	Screw Conveyor Components										MB	NB	OB	PB	QB	UB †
	Cplg Dia	Screw Dia	Max Tq lb-in	Drive Shaft w/Thrust Plate ‡	Part No.	Wt lb	Seal Housing Accessory Kit ▲	Part No.	Wt lb							
5407	3.000	14-20	34,300	DS5407J-3.000 *	6720035	74	SH5407J	0757205	2.5	1.875	1.000	3.000	0.781	10.00 *	3.000	
	3.438	16-24	51,400	DS5407J-3.437 *	6720036	89	SH5407J	0757205	2.5	2.375	1.500	4.000	0.906	13.28 *	3.437	

★ † ‡ (See footnotes on Page 17.)

* (See footnote on Page 19.)

▲ Consists of waste packing and trough end gasket.

Trough End Seals

Lip Seal
PN 2913658
Wt. 1 lb.

Waste Packing
Std.-Included with seal housing accessory kit.
PN 0925058
Wt. 1 lb.

Size 5407/Dimensions – Inches

Motor Mounts ★

Standard Horizontal Drive Assembly – 3 o'clock (A3)

Refer to Page 48 for minimum and maximum shaft centers for bottom and side mounting. The assemblies may also be rotated about the hollow shaft in 90° increments to position the input shaft in 3, 6, 9 and 12 o'clock positions, ±10° and mounted vertically.

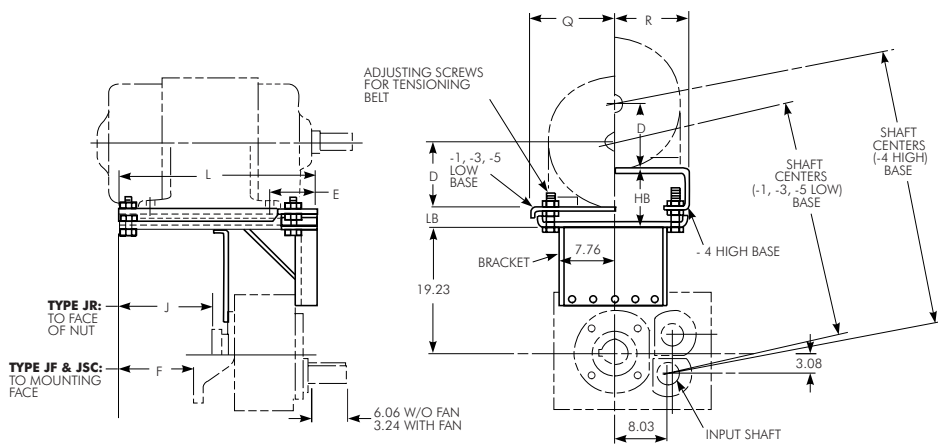

A3

C3

D3

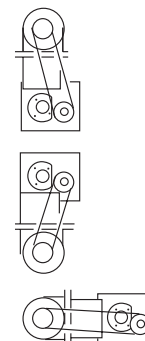

Frame	56	143-145T	182-184T	213-215T	254-256T	284-286T	324-326	364-365T	404-405	444-449T
D	3.50	3.50	4.50	5.25	6.25	7.00	8.00	9.00	10.00	11.00
E	2.68	2.50	2.50	3.25	4.18	4.69	5.19	5.81	6.56	7.45
Shaft Centers †	Min-Max	Min-Max	Min-Max	Min-Max	Min-Max	Min-Max	Min-Max	Min-Max	Min-Max	Min-Max
-1 Low Base	28.0-31.9	28.0-31.9	28.9-32.9	29.6-33.6
-3 Low Base	31.4-35.1	32.1-35.8	33.0-36.8	34.0-37.7	35.0-38.7	...
-4 High Base	35.1-38.9	35.8-39.6	36.8-40.6	37.8-41.5	38.8-42.5	...
-5 Low Base	37.2-40.7

† Shaft centers can be increased up to 1½ inches with shim blocks. See Page 49 for shim blocks.

MOTOR MOUNT SIZE ★	Part Number	Type T Frame		F	J	L	Q	R	HB	LB	Motor Mount Wt-lb
		Min	Max						Min-Max	Min-Max	
MM5407J-1	0757620	56	215	0.18	0.51	15.00	8.16	1.02-4.84	80
MM5407J-3	0757621	254	405	11.46	11.77	26.26	11.88	2.12-5.96	193
MM5407J-4	0757622	254	405	11.46	11.77	26.26	...	11.62	6.00-9.84	...	215
MM5407J-5	0786584	444	449	19.20	19.56	34.00	16.00	3.37-7.00	325

★ (See footnote on Page 17.)

Size 5415/Dimensions – Inches

Shaft Mounted (JR) Drive ★

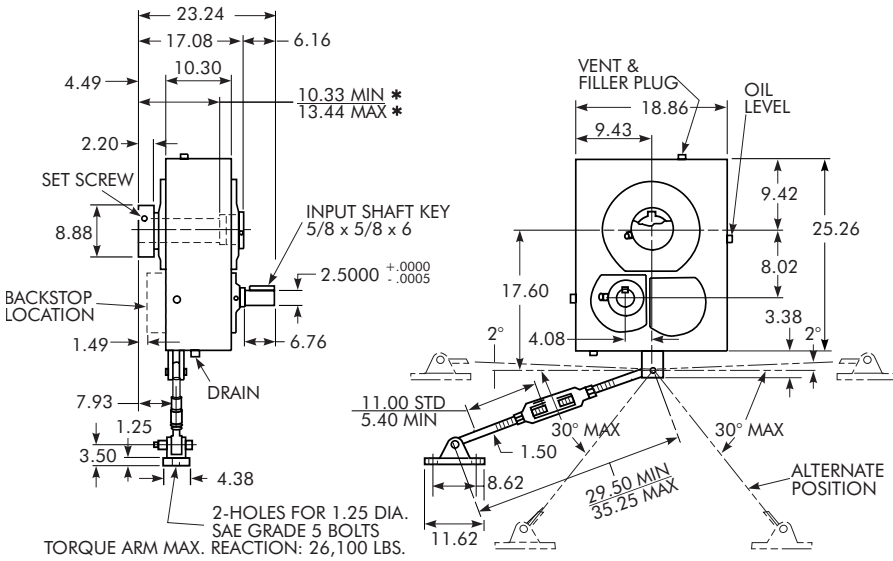

Shaft Fan Kit
SFK5415J
PN 0785881
Wt. 4 lb.

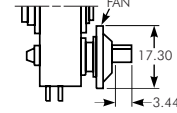

Drive Mounting Positions

(Based on clock position of input shaft relative to hollow shaft.)

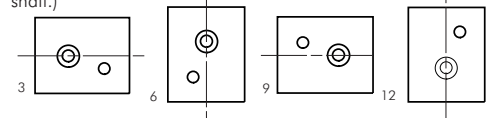

Hollow Shaft Details

See Manual 377-140 for JF drive tapered driven shaft recommendations. See Manual 377-144 for JF drives using tapered bushings.

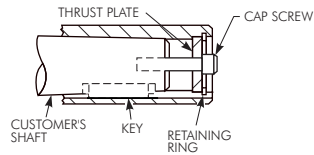

Angular Limits For Horizontal Mounting

(All Clock Positions)

Refer to Factory for lubrication analysis of all inclined drives exceeding the maximum specified below.

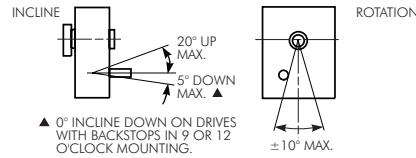

DRIVE SIZE †	Part Number	Exact Ratio	Max Output rpm	Wt lb
5415JR05	0794698	5.077	350	765
5415JR14A	0794699	13.61	125	795
5415JR25A	0794700	26.11	70	795

* (See footnote on Page 16.)

† (See footnote on Page 30.)

TA Taper Bushings

Style No. 1 — Thin-wall bushing

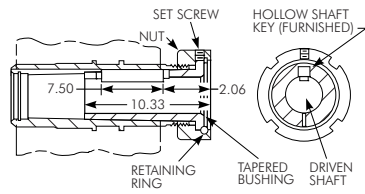

Style No. 2 — Thick-wall bushing

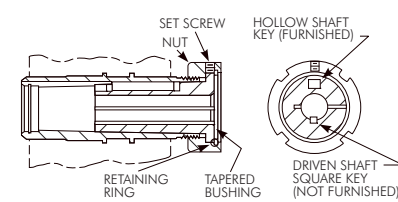

BUSHING SIZE	Part Number †	Style No.	Driven Shaft Keyway/Min Key Length *	Wt lb
BU5415J-3.438	0769234	2	7/8 X 7/16 X 8	41.5
BU5415J-3.938	0769235	2	1 X 1/2 X 6	33.8
BU5415J-4.188	0769236	1	1 X 1/2 X 7 1/2	29.5
BU5415J-4.438	0769237	1	1 X 1/2 X 7 1/2	24.9
BU5415J-4.938	0769238	1	1 1/4 X 5/8 X 7 1/2	15.1

† ● (See footnotes on Page 16.)

Accessories

Torque Arm
TA5415J
PN 0785272
Wt. 56 lb.

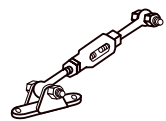

Backstop ■
BS5415J14
PN 0757220
BS5415J25
PN 0757221
Wt. 22 lb.

■ Not available in 5:1 ratio.



Thrust Plate Kit
TP5415J
PN 0769233
Wt. 8 lb.



Vertical Breather
VB5415J-HSS Up W/O Fan
PN 0757223
VB5415J-HSS Down W/O Fan
PN 0757224
VB5415J-HSS Up With Fan
PN 0765841
VB5415J-HSS Down With Fan
PN 0765842
Wt. 8 lb.



Vertical Drives

Refer to Factory for lubrication analysis of all vertical drives exceeding ±1° from true vertical.

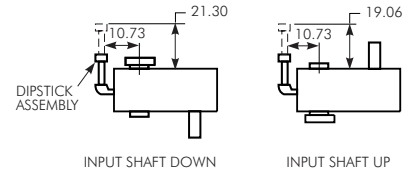

Size 5415/Dimensions – Inches

Flange Mounted (JF) Drive ★

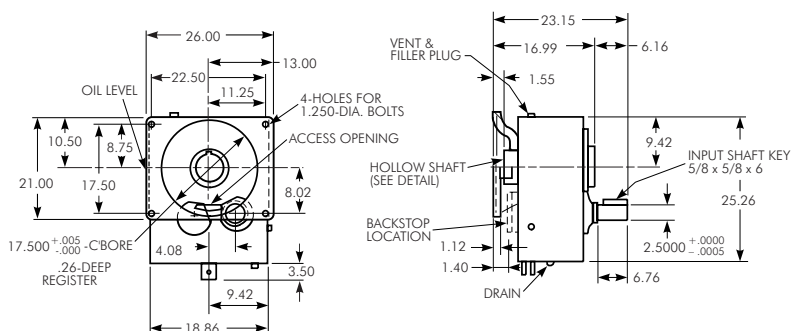

DRIVE SIZE †	Part Number	Exact Ratio	Max Output rpm	Wt lb
5415JF05A	0794397	5.077	350	890
5415JF14A	0794398	13.61	125	920
5415JF25A	0794399	26.11	70	920

† (See footnote on Page 31.)

Motor Mounts

Standard Horizontal Drive Assembly – 3 o'clock (A3)

Refer to Page 48 for minimum and maximum shaft centers for bottom and side mounting positions. The assemblies may also be rotated about the hollow shaft in 90° increments to position the input shaft in 3, 6, 9 and 12 o'clock positions, ±10° and mounted vertically.

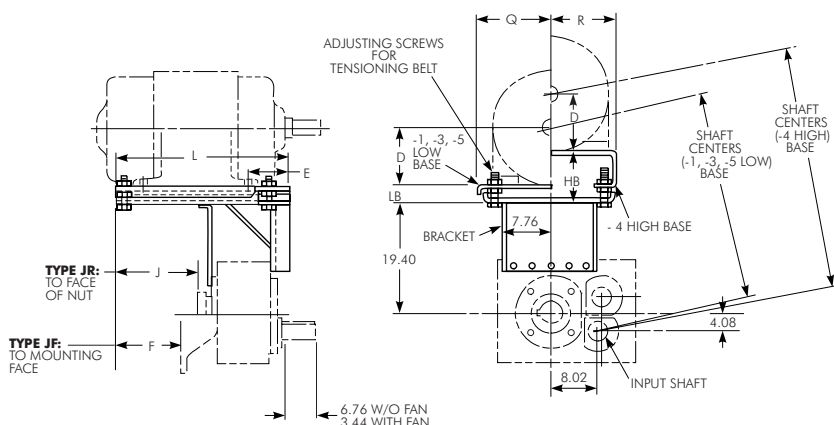

A3



C3



D3



Frame	56	143-145T	182-184T	213-215T	254-256T	284-286T	324-326T	364-365T	404-405	444-449T
D	3.50	3.50	4.50	5.25	6.25	7.00	8.00	9.00	10.00	11.00
E	2.68	2.18	2.68	3.44	4.18	4.69	5.19	5.81	6.56	7.45
Shaft Centers ‡	Min-Max	Min-Max	Min-Max	Min-Max	Min-Max	Min-Max	Min-Max	Min-Max	Min-Max	Min-Max
-1 Low Base	29.5-33.2	29.5-33.2	30.4-34.2	31.2-34.9
-3 Low Base	32.7-36.5	33.5-37.3	34.4-38.3	35.4-39.2	36.4-40.2	...
-4 High Base	36.6-40.3	37.6-41.1	38.3-42.1	39.3-43.0	40.3-44.0	...
-5 Low Base	38.7-42.3

‡ (See footnote on Page 33.)

MOTOR MOUNT SIZE ★	Part Number		Type T Frame		F	J	L	Q	R	HB	LB	Motor Mount Wt-lb
	JR	JF	Min	Max						Min-Max	Min-Max	
MM5415J-1	0757623	0757624	56	215	1.70 ■	1.82 ◆	15.00	8.16	1.02-4.84	88
MM5415J-3	0757625	0757627	254	405	9.59	9.47	26.26	11.88	2.14-5.96	196
MM5415J-4	0757626	0757628	254	405	9.59	9.47	26.26	...	11.62	6.00-9.80	...	218
MM5415J-5	0786638	0786639	444	449	17.33	17.21	34.00	16.00	3.37-7.00	325

★ (See footnote on Page 17.)

■ The drive mounting surface (or seal housing) extends beyond the motor mount by the value shown.

◆ Protrudes beyond the motor mount.

Size 5507/Dimensions – Inches

Shaft Mounted (JR) Drive ★

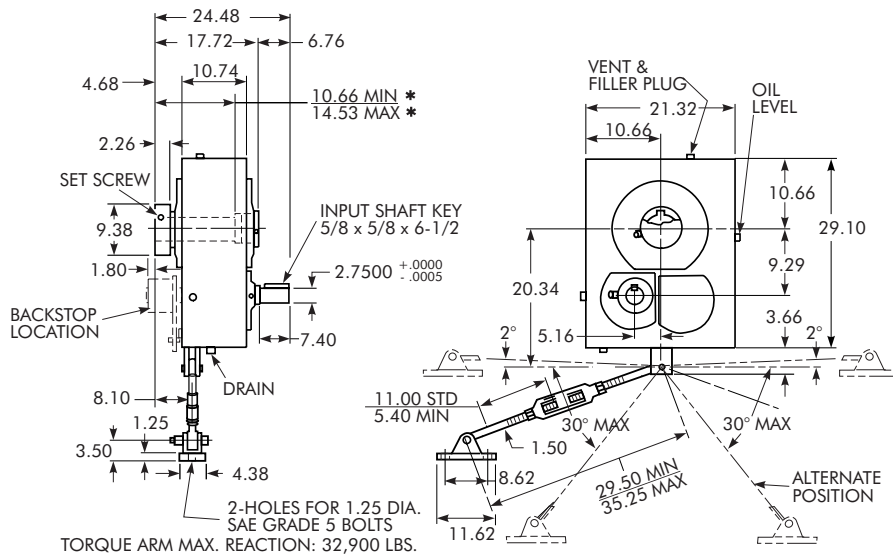

Shaft Fan Kit
 SFK5507J
 PN 0785893
 Wt. 5 lb.

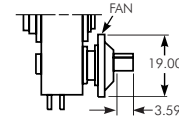

Drive Mounting Positions

(Based on clock position of input shaft relative to hollow shaft.)

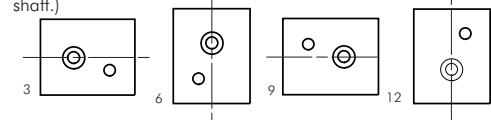

Hollow Shaft Details

See Manual 377-140 for JF drive tapered driven shaft recommendations. See Manual 377-144 for JF drives using tapered bushings.

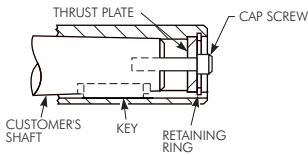

Angular Limits For Horizontal Mounting

(All Clock Positions)

Refer to Factory for lubrication analysis of all inclined drives exceeding the maximum specified below.

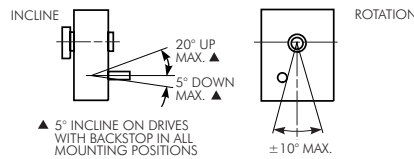

DRIVE SIZE †	Part Number ♦			Exact Ratio	Max Output rpm	Wt lb
	W/O Backstop	With Backstop	For Backstop			
5507JR05A	0794406	4.929 ■	350	...
5507JR14A	0794407	0795667	0794409	13.46	125	1065
5507JR25A	0794408	0795668	0794410	24.29	70	1065

* (See footnote on Page 16.)

† (See footnote on Page 30.)

■ Non-stock, Refer to Factory.

♦ These part numbers do not include bushing.

TA Taper Bushings

Style No. 1 — Thin-wall bushing

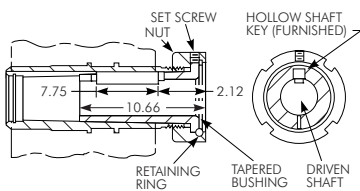

Style No. 2 — Thick-wall bushing

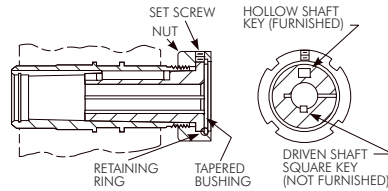

BUSHING SIZE	Part Number ‡	Style No.	Driven Shaft Keyway/Min Key Length •	Wt lb
BU5507J-3.438	0786824	2	7/8 x 7/16 x 10	56.8
BU5507J-3.938	0786825	2	1 x 1/2 x 10	48.8
BU5507J-4.438	0786826	2	1 x 1/2 x 10	40.0
BU5507J-4.938	0785894	1	1 1/4 x 5/8 x 7 3/4	40.0
BU5507J-5.438	0785895	1	1 1/4 x 5/8 x 7 3/4	18.2

‡ • (See footnotes on Page 16.)

Accessories

Torque Arm

TA5507J
 PN 0785272
 Wt. 56 lb.

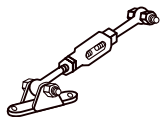

Backstop

BS4507J14
 #0793687
 BS4507J25
 #0793688

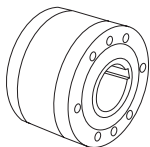

Thrust Plate Kit

TP5507J
 PN 0769221
 Wt. 9 lb.



Vertical Breather

VB5507J-HSS Up W/O Fan
 PN 0757223
 VB5507J-HSS Down W/O Fan
 PN 0757224
 VB5507J-HSS Up With Fan
 PN 0765841
 VB5507J-HSS Down With Fan
 PN 0765842
 Wt. 8 lb.



Vertical Drives

Refer to Factory for lubrication analysis of all vertical drives exceeding ±1° from true vertical.

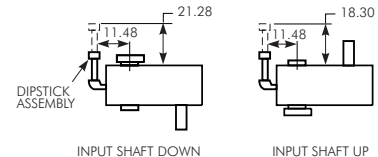

Size 5507/Dimensions – Inches

Flange Mounted (JF) Drive ★ (Not available with backstop)

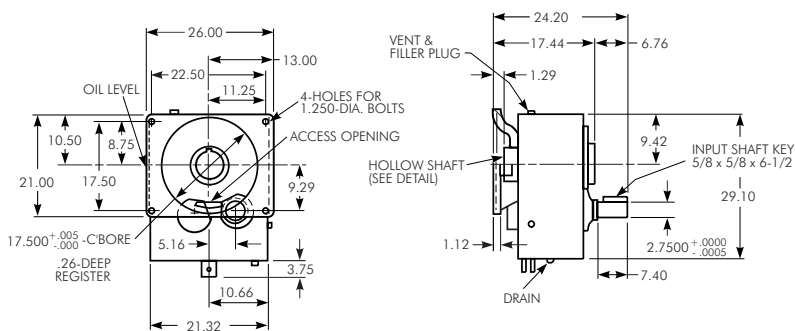

DRIVE SIZE †	Part Number	Exact Ratio	Max Output rpm	Wt lb
5507JF05A	0794411	4.929 *	350	...
5507JF14A	0794412	13.46	125	1200
5507JF25A	0794413	24.29	70	1200

† (See footnote on Page 31.)

* Non-stock, Refer to Factory.

Motor Mounts

Standard Horizontal Drive Assembly – 3 o'clock (A3)

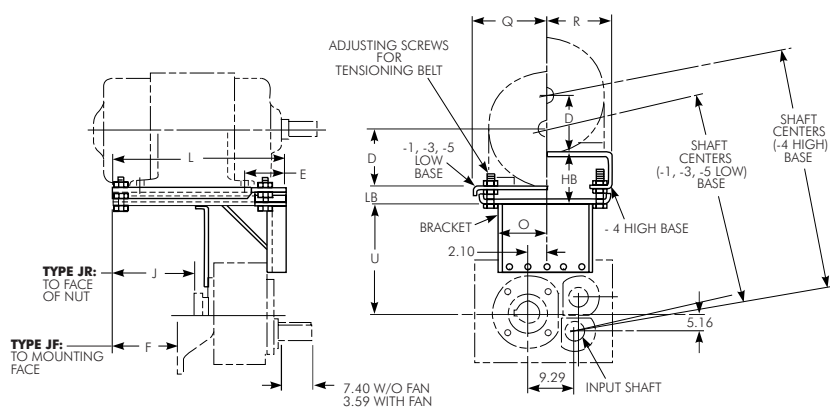

Refer to Page 48 for minimum and maximum shaft centers for bottom and side mounting positions. The assemblies may also be rotated about the hollow shaft in 90° increments to position the input shaft in 3, 6, 9 and 12 o'clock positions, ±10° and mounted vertically.

A3



C3



D3

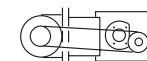

Frame	56	143-145T	182-184T	213-215T	254-256T	284-286T	324-326T	364-365T	404-405T	444-449T
D	3.50	3.50	4.50	5.25	6.25	7.00	8.00	9.00	10.00	11.00
E	2.68	2.18	2.68	3.44	4.18	4.69	5.19	5.81	6.56	7.44
Shaft Centers ‡	Min-Max	Min-Max	Min-Max	Min-Max	Min-Max	Min-Max	Min-Max	Min-Max	Min-Max	Min-Max
-1 Low Base	31.5-35.5	31.5-35.5	32.5-36.5	33.2-37.2
-3 Low Base	34.9-38.7	35.7-39.4	36.6-40.4	37.6-41.4	38.6-42.4	...
-4 High Base	38.7-42.5	39.5-43.2	40.5-44.2	41.4-45.2	42.4-46.2	...
-5 Low Base	46.1-49.8

‡ (See footnote on Page 33.)

MOTOR MOUNT SIZE *	Part Number		Type T Frame		F	J	L	O	Q	R	U	HB	LB	Motor Mount Wt-lb
	JR	JF	Min	Max								Min-Max	Min-Max	
MM5507J-1	0757239	0757240	56	215	2.17 ■	2.51 ◆	15.00	7.76	8.16	...	21.03	...	1.02-5.08	111
MM5507J-3	0757241	0757243	254	405	9.12	8.78	26.26	7.76	11.88	...	20.64	...	2.12-5.96	224
MM5507J-4	0757242	0757244	254	405	9.12	8.78	26.26	7.76	...	11.62	20.64	6.00-9.84	...	246
MM5507J-5	0769048	0769049	444	449	16.47	16.15	34.00	11.25	16.00	...	27.41	...	2.00-5.75	438

● (See footnote on Page 17.)

■ ◆ (See footnotes on Page 35.)

Size 5608/Dimensions – Inches

Shaft Mounted (JR) Drive ★

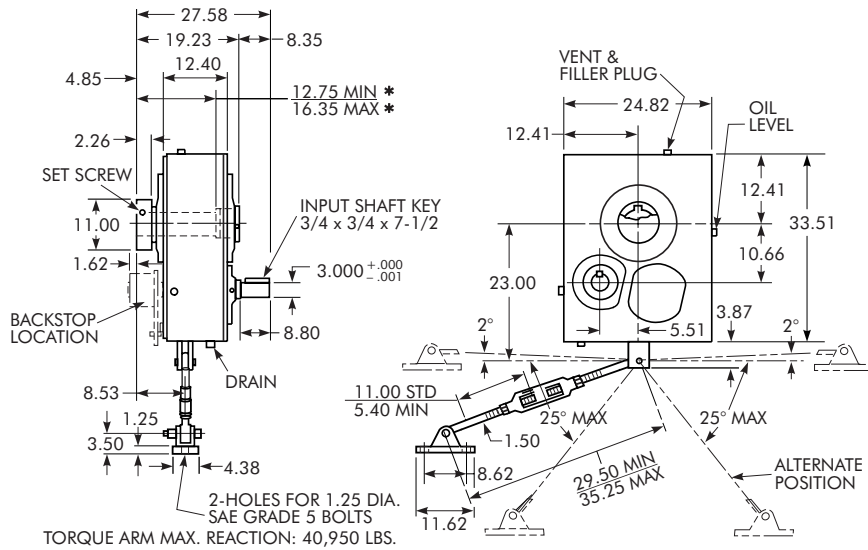

Shaft Fan Kit
SFK5608J
PN 0785468
Wt. 5 lb.

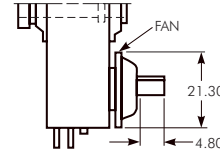

Hollow Shaft Details

See Manual 377-140 for JF drive tapered driven shaft recommendations. See Manual 377-144 for JF drives using tapered bushings.

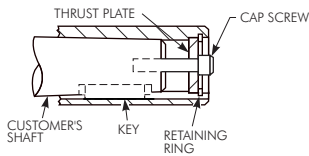

Angular Limits For Horizontal Mounting

(All Clock Positions)

Refer to Factory for lubrication analysis of all inclined drives exceeding the maximum specified below.

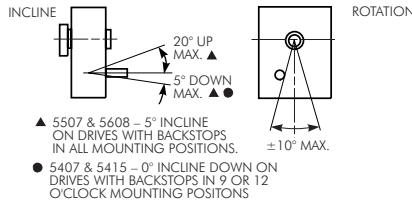

DRIVE SIZE †	Part Number ♦			Exact Ratio	Max Output rpm	Wt lb
	W/O Backstop	With Backstop	For Backstop			
5608JR05A	0794701	5.00 ■	350	...
5608JR14A	0794702	0794704	0794420	13.82	125	1800
5608JR25A	0794703	0794705	0794421	25.33	70	1800

* (See footnote on Page 16.)
† (See footnote on Page 30.)
■ (See footnote on Page 36.)
★ (See footnote on Page 17.)
♦ These part numbers do not include bushing.

TA Taper Bushings

Style No. 1 — Thin-wall bushing

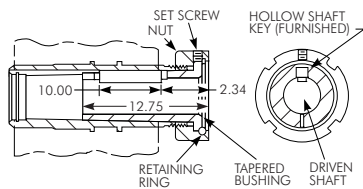

BUSHING SIZE	Part Number ‡	Style No.	Driven Shaft Keyway/Min Key Length ●	Wt lb
BU5608J-5.437	0769737	1	1/4 x 5/8 x 10	64.5
BU5608J-5.937	0769738	1	1/2 x 3/4 x 10	49.6
BU5608J-6.437	0765847	1	1/2 x 3/4 x 10	30.0
BU5608J-6.500	0769739	1	1/2 x 3/4 x 10	31.4

‡ ● (See footnotes on Page 16.)

Size 5608/ Dimensions – Inches

Flange Mounted (JF) Drive ★ (Not available with backstop)

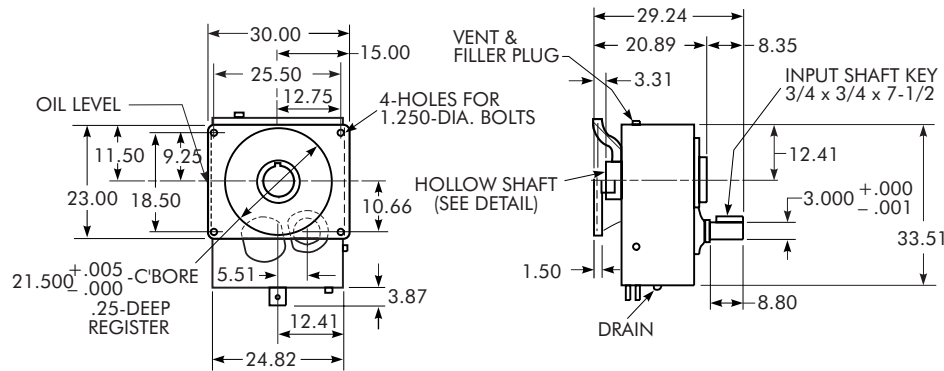

DRIVE SIZE †	Part Number	Exact Ratio	Max Output rpm	Wt lb
5608JF05A	0794414	5.00 ‡	350	2100
5608JF14A	0794415	13.82	125	2100
5608JF25A	0794416	25.33	70	2100

† (See footnote on Page 31.)
 ‡ Non-stock, Refer to Factory.

Drive Mounting Positions

(Based on clock position of input shaft relative to hollow shaft.)

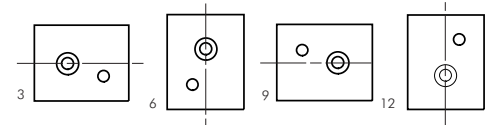

Accessories

Torque Arm

TA5608J
 PN 0785272
 Wt. 56 lb.

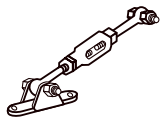

Backstop

BS4608J14
 BS4608J25
 #0793687

■ Not available with 5:1 ratios.

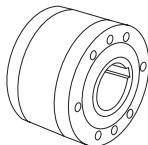

Thrust Plate Kit

TP5608J
 PN 0769740
 Wt. 10 lb.



Vertical Breather

VB5608J-HSS Up W/O Fan
 PN 0785474
 VB5608J-HSS Down W/O Fan
 PN 0757224
 VB5608J-HSS Up With Fan
 PN 0786718
 VB5608J-HSS Down With Fan
 PN 0765842
 Wt. 8 lb.



Vertical Drives

Refer to Factory for lubrication analysis of all vertical drives exceeding ±1° from true vertical.

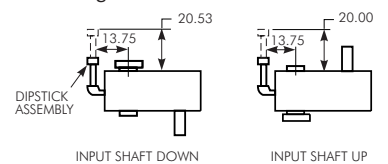

Size 5608/Dimensions – Inches

Motor Mounts ★

Standard Horizontal Drive Assembly – 3 o'clock (A3)

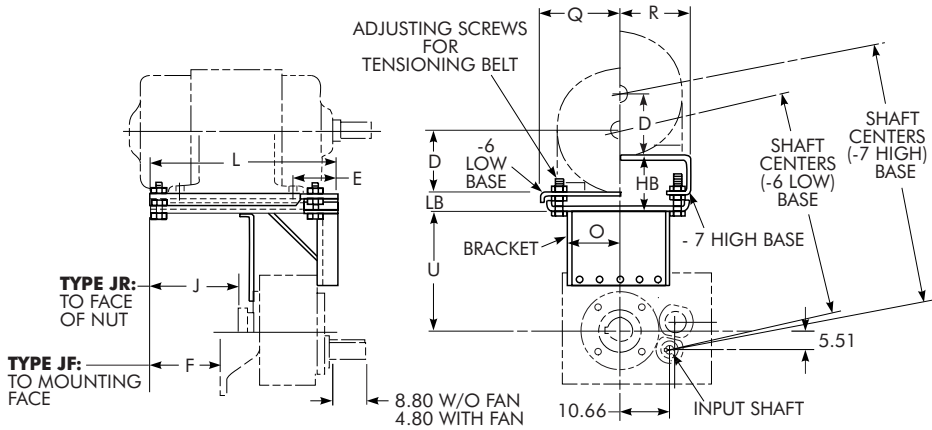

Refer to Page 48 for minimum and maximum shaft centers for bottom and side mounting positions. The assemblies may also be rotated about the hollow shaft in 90° increments to position the input shaft in 3, 6, 9 and 12 o'clock positions, ±10° and mounted vertically.

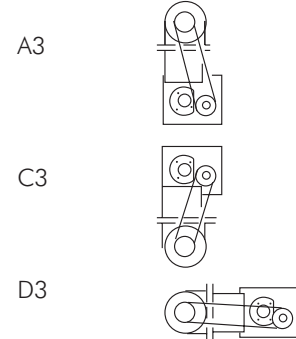

Frame	254-256T	284-286T	324-326T	364-365T	404-405T	444-449T
D	6.25	7.00	8.00	9.00	10.00	11.00
E	4.00	4.75	5.25	6.00	6.75	7.50
Shaft Centers ‡	Min-Max	Min-Max	Min-Max	Min-Max	Min-Max	Min-Max
-6 Low Base	43.5-47.0	44.3-47.8	45.2-48.8	46.2-49.7	47.2-50.7	48.1-51.7
-7 High Base	47.2-50.8	47.9-51.6	48.9-52.5	49.9-53.5	50.8-54.5	...

‡ (See footnote on Page 33.)

MOTOR MOUNT SIZE ★	Part Number		Type T Frame		F	J	L	O	Q	R	U	HB	LB	Motor Mount Wt-lb
	JR	JF	Min	Max								Min-Max	Min-Max	
MM5608J-6 MM5608J-7	0786722	0786723	254	449	12.71	14.38	34.00	13.50	16.00	...	27.06	...	3.38-7.00	450
	0786720	0786721	254	405	12.71	14.38	34.00	13.50	...	15.12	27.06	7.13-10.87	...	460

★ (See footnote on Page 17.)

Screw Conveyor Options/Dimensions – Inches

TROUGH ENDS — Sizes 6 through 24 inches ★

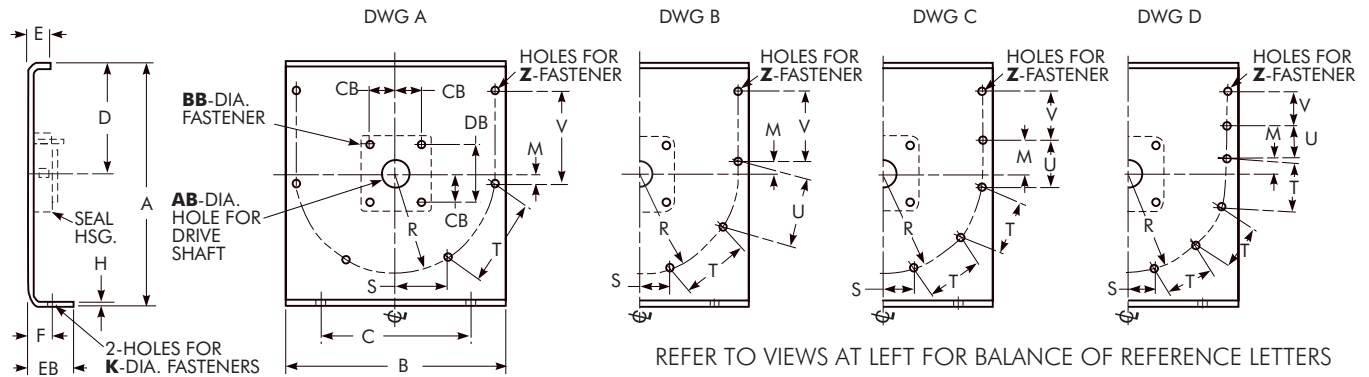

REFER TO VIEWS AT LEFT FOR BALANCE OF REFERENCE LETTERS

SCREW SIZE	Drive Shaft Dia	Type JSC Size Range	Part Number	Above Dwg	AB	BB †	CB	DB	EB	A	B	C	D	E	F	H	K	M	R	S	T	U	V	Wt lb
6	1.500	5107-5203	0359263	A	2.25	.500	2.000	4.000	1.8	10.1	10.0	8.125	4.5	1.50	1.000	.188	.375	.638	4.438	2.032	4.062	...	4.125	7
	2.000	5107-5215	0359264 0359265	B	2.25	.500	2.000	4.000	2.6	14.0	13.7	9.375	6.1	1.62	1.500	.250	.500	.821	6.250	2.562	3.750	4.125	4.125	18
12	2.000	5107-5215	0359266	B	2.25	.625	2.562	5.125	2.8	17.4	17.3	12.250	7.8	2.00	1.625	.312	.625	.938	7.938	3.875	4.062	5.188	5.312	31
	2.438	5107-5315	0359272	B	2.56	.625	2.812	5.625	2.8	17.4	17.3	12.250	7.8	2.00	1.625	.312	.625	.938	7.938	3.875	4.062	5.188	5.312	31
	3.000	5107-5315	0359273	B	3.12	.750	3.000	6.000	2.8	20.1	19.3	16.500	9.3	2.00	1.625	.312	.625	1.107	8.938	3.000	5.938	5.938	5.625	39
14	2.438	5107-5315	0359274	B	2.56	.625	2.812	5.625	2.9	20.1	19.3	16.500	9.3	2.00	1.625	.312	.625	1.107	8.938	3.000	5.938	5.938	5.625	39
	3.000	5107-5315	0359275	B	3.12	.750	3.000	6.000	2.9	20.1	19.3	16.500	9.3	2.00	1.625	.312	.625	1.107	8.938	3.000	5.938	5.938	5.625	39
	3.000	5407	0359267	B	4.25	.750	4.625	9.250	2.6	22.6	21.3	14.875	10.6	2.50	2.000	.312	.625	1.609	10.000	3.750	6.625	9.625	6.375	51
16	3.000	5107-5315	0359276	B	3.12	.750	3.000	6.000	3.3	22.6	21.3	14.875	10.6	2.50	2.000	.312	.625	1.609	10.000	3.750	6.625	9.625	6.375	51
	3.000	5407	0359268	B	4.25	.750	4.625	9.250	2.7	22.6	21.3	14.875	10.6	2.50	2.000	.312	.625	1.609	10.000	3.750	6.625	9.625	6.375	51
	3.438	5407	0359268	B	4.25	.750	4.625	9.250	2.7	22.6	21.3	14.875	10.6	2.50	2.000	.312	.625	1.609	10.000	3.750	6.625	9.625	6.375	51
	3.438	5407	0359269	B	4.25	.750	4.625	9.250	2.7	22.6	21.3	14.875	10.6	2.50	2.000	.312	.625	1.609	10.000	3.750	6.625	9.625	6.375	51
18	3.000	5107-5315	0359277	C	3.12	.750	3.000	6.000	3.3	25.5	24.3	16.000	12.1	2.50	2.000	.375	.625	3.478	11.000	2.938	5.875	5.875	5.938	73
	3.438	5215-5315	0359278	C	3.56	.750	3.375	6.750	3.3	25.5	24.3	16.000	12.1	2.50	2.000	.375	.625	3.478	11.000	2.938	5.875	5.875	5.938	73
	3.000	5407	0359269	C	4.25	.750	4.625	9.250	2.7	25.5	24.3	16.000	12.1	2.50	2.000	.375	.625	3.478	11.000	2.938	5.875	5.875	5.938	73
	3.438	5407	0359269	C	4.25	.750	4.625	9.250	2.7	25.5	24.3	16.000	12.1	2.50	2.000	.375	.625	3.478	11.000	2.938	5.875	5.875	5.938	73
20	3.000	5107-5315	0359279	C	3.12	.750	3.000	6.000	3.8	28.5	26.3	19.250	13.5	2.50	2.250	.375	.750	4.489	12.188	3.344	6.688	6.688	6.250	91
	3.438	5215-5315	0359280	C	3.56	.750	3.375	6.750	3.8	28.5	26.3	19.250	13.5	2.50	2.250	.375	.750	4.489	12.188	3.344	6.688	6.688	6.250	91
	3.000	5407	0359270	C	4.25	.750	4.625	9.250	3.4	28.5	26.3	19.250	13.5	2.50	2.250	.375	.750	4.489	12.188	3.344	6.688	6.688	6.250	91
	3.438	5407	0359270	C	4.25	.750	4.625	9.250	3.6	28.5	26.3	19.250	13.5	2.50	2.250	.375	.750	4.489	12.188	3.344	6.688	6.688	6.250	91
24	3.438	5215-5315	0359281	D	3.56	.750	3.375	6.750	4.1	34.6	30.3	20.000	16.5	2.50	2.500	.375	.750	1.011	14.250	3.312	6.625	6.625	6.125	126
	3.438	5407	0359271	D	4.25	.750	4.625	9.250	4.1	34.6	30.3	20.000	16.5	2.50	2.500	.375	.750	1.011	14.250	3.312	6.625	6.625	6.125	126

★ (See footnote on Page 17.)

† Hex head screws are furnished with Falk drive shafts.

316 Stainless † Steel Drive Shafts •

Description	Part No.	Description	Part No.
5107JSC Drive Shafts		5215JSC Drive Shafts	
DSS5107-1.500	6720054	DSS5215J-2.000	6720071
DSS5107-2.000	6720055	DSS5215J-2.438	6720072
DSS5107-2.438	6720056	DSS5215J-3.000	6720073
DSS5107-3.000	6720057	DSS5215J-3.438	6720074
5115JSC Drive Shafts		5307JSC Drive Shafts	
DSS5115-1.500	6720058	DSS5307J-2.438	6720075
DSS5115-2.000	6720059	DSS5307J-3.000	6720076
DSS5115-2.438	6720060	DSS5307J-3.438	6720077
DSS5115-3.000	6720061		
5203JSC Drive Shafts		5315JSC Drive Shafts	
DSS5203-1.500	6720062	DSS5315J-2.438	6720078
DSS5203-2.000	6720063	DSS5315J-3.000	6720079
DSS5203-2.438	6720064	DSS5315J-3.438	6720080
DSS5203-3.000	6720065		
5207JSC Drive Shafts		5407JSC Drive Shafts	
DSS5207-1.500	6720066	DSS5407J-3.000	6720081
DSS5207-2.000	6720067	DSS5407J-3.438	6720081
DSS4207-2.438	6720068		
DSS5207-3.000	6720069		
DSS5207-3.438	6720070		

† Check torque & bending capacity of driven shaft and coupling bolt shear against load. Mechanical properties of stainless steel differ from those of carbon steel.

• Furnished with thrust plate kit and stainless steel trough end-to-seal housing fasteners.

Holes for Z-Fasteners

SCREW SIZE	6	9	12	14	16	18	20	24
No.	6	8	8	8	8	10	10	12
Dia	.375	.375	.500	.500	.625	.625	.625	.625

Taper Conversion Bushing (TCB) Kits ■

Description ♦	Part No.
TCB5107-1.438	0766041
TCB5115-1.938	0766042
TCB5203-2.188	0766043
TCB5207-2.438	0766044
TCB5215-2.938	0766045
TCB5307-3.438	0766046
TCB5315-3.438	0785785
TCB5407-3.438	0786823

■ Refer to Manual 377-146 for details.

♦ Kit consists of: Bushing, thrust plate, fastener, key, retaining ring, and hardware.

Nominal Sheave Ratios and V-Belts

Sheave Ratios — The table below lists the sheave ratios for nominal gear drive ratios and output speeds when driven by 1750 and 1170 rpm motors. If sheave ratios are required for other motor speeds, or if greater accuracy than ±3% is required for the output speed, calculate the sheave ratio with the following formula, using the exact gear ratios. Check the sheave pitch diameter against the allowable minimums in Selection Tables 2, 3 and 4.

$$\text{Sheave ratio} = \frac{\text{Exact Motor Speed}}{\text{Exact Gear Drive Ratio} \times \text{Required Output Speed}}$$

Drive Ratio Substitution — Selections in Tables 2, 3 and 4 list the most economical choice of drive size and ratio for a given output speed using 1750 or 1170 rpm motors. Standard drive ratios (not drive sizes) can be substituted in recommended drives. See Table 5, Page 13.

V-Belts — Selections can be made from any belt manufacturer's catalog. If a Falk motor mount is used, refer to Pages 16 thru 40 for dimensions and shaft centers. When determining belt length and minimum center distance, include belt installation allowance in calculations.

TABLE 12 — Nominal Sheave Ratios ★

Drive Output rpm	5:1 Drive		Drive Output rpm	9:1 Drive		Drive Output rpm	14:1 Drive		Drive Output rpm	25:1	
	Motor rpm			Motor rpm			Motor rpm			Motor rpm	
	1750	1170		1750	1170		1750	1170		1750	1170
372	1.06	...	230	1.19	...	160	1.28	...	80	1.14	...
362	1.03	...	216	1.10	...	155	1.23	...	76	1.09	...
356	1.02	1.52	204	1.05	...	150	1.20	...	73	1.04	...
350	1.00	1.50	194	1.00	1.51	146	1.16	...	70	1.00	...
338	1.04	1.44	191	1.02	1.47	139	1.11	...	69	1.01	...
330	1.06	1.41	180	1.08	1.39	135	1.08	...	67	1.04	...
323	1.08	1.38	172	1.13	1.33	130	1.04	...	64	1.09	...
314	1.11	1.34	162	1.20	1.25	125	1.00	1.52	62	1.13	...
307	1.14	1.31	153	1.27	1.19	120	1.04	1.45	61	1.15	...
302	1.16	1.29	148	1.31	1.15	118	1.06	1.43	59	1.19	...
290	1.21	1.24	140	1.39	1.09	113	1.11	1.37	58	1.21	...
286	1.22	1.22	135	1.44	1.04	109	1.15	1.32	57	1.23	...
280	1.25	1.20	129	1.50	1.00	106	1.18	1.28	56	1.25	...
276	1.27	1.18	125	1.55	1.03	100	1.25	1.20	55	1.27	...
272	1.29	1.16	115	1.69	1.12	98	1.28	1.18	54	1.30	...
268	1.31	1.15	108	1.80	1.19	95	1.32	1.15	53	1.32	...
259	1.35	1.11	101	1.92	1.28	92	1.36	1.11	52	1.35	...
251	1.39	1.07	95	2.04	1.36	89	1.40	1.07	50	1.40	...
244	1.43	1.04	91	2.13	1.42	86	1.45	1.03	48	1.46	...
241	1.45	1.03	88	2.20	1.47	83	1.51	1.00	46	1.52	1.00
237	1.48	1.01	85	2.28	1.52	79	1.58	1.05	45	1.56	1.03
234	1.50	1.00	84	2.31	1.54	76	1.64	1.09	44	1.59	1.05
228	1.54	1.03	80	2.43	1.61	74	1.69	1.12	43	1.63	1.08
223	1.57	1.05	77	2.52	1.68	70	1.79	1.19	42	1.67	1.10
220	1.59	1.06	74	2.62	1.74	69	1.81	1.20	41	1.71	1.13
216	1.62	1.08	71	2.73	1.82	67	1.87	1.24	40	1.75	1.16
210	1.67	1.11	69	2.81	1.87	64	1.95	1.30	39	1.79	1.19
206	1.70	1.14	67	2.90	1.93	60	2.08	1.38	38	1.84	1.22
204	1.72	1.15	64	3.03	2.02	58	2.16	1.43	37	1.89	1.25
201	1.74	1.16	62	3.13	2.08	56	2.23	1.48	36	1.94	1.29
196	1.79	1.19	61	3.18	2.11	54	2.31	1.54	35	2.00	1.32
192	1.82	1.22	60	3.23	2.15	52	2.40	1.60	34	2.06	1.36
185	1.89	1.26	59	3.29	2.19	50	2.50	1.66	33	2.12	1.40
180	1.94	1.30	58	3.34	2.22	48	2.60	1.73	32	2.19	1.45
174	2.01	1.34	57	3.40	2.26	46	2.72	1.80	31	2.26	1.49
172	2.03	1.36	56	3.46	2.30	45	2.78	1.84	30	2.33	1.54
168	2.08	1.39	55	3.53	2.34	44	2.84	1.89	29	2.41	1.60
164	2.13	1.43	54	3.59	2.39	43	2.91	1.93	28	2.50	1.65
160	2.19	1.46	53	3.66	2.43	42	2.98	1.98	27	2.59	1.71
157	2.23	1.49	52	3.73	2.48	41	3.05	2.02	26	2.69	1.78
151	2.32	1.55	51	3.80	2.53	40	3.13	2.08	25	2.80	1.85
146	2.40	1.60	50	3.88	2.58	39	3.21	2.13	24	2.92	1.93
141	2.48	1.66	49	3.96	2.63	38	3.29	2.18	23	3.04	2.01
133	2.63	1.76	48	4.04	2.69	37	3.38	2.24	22	3.18	2.10
126	2.78	1.86	47	4.13	2.74	36	3.47	2.31	21	3.33	2.20
122	2.87	1.92	46	4.22	2.80	35	3.57	2.37	20	3.50	2.32
118	2.97	1.98	45	4.31	2.87	34	3.68	2.44	19	3.68	2.44
114	3.07	2.05	44	4.41	2.93	33	3.79	2.52	18	3.89	2.57
108	3.24	2.17	43	4.51	3.00	32	3.91	2.59	17	4.12	2.72
103	3.40	2.27	42	4.62	3.07	31	4.03	2.68	16	4.38	2.89
101	3.47	2.32	41	4.73	3.15	30	4.17	2.77	15	4.67	3.09
97	3.61	2.41	40	4.85	3.23	29	4.31	2.86	14	5.00	3.31
94	3.72	2.49	39	4.97	3.31	28	4.46	2.96	13	5.38	3.56
92	3.80	2.54	38	5.11	3.39	27	4.63	3.07	12	5.83	3.86
90	3.89	2.60	37	5.24	3.49	26	4.81	3.19	11	6.36	4.21
			36	5.39	3.58	25	5.00	3.32	10	...	4.63
			35	5.54	3.69	24	5.21	3.46	9	...	5.14
			34	5.71	3.79	23	5.43	3.61	8	...	5.79
			33	5.88	3.91	22	5.68	3.77	7	...	6.62
			32	6.06	4.03	21	5.95	3.95	6	...	7.7
			31	...	4.16	20	6.25	4.15	5	...	9.3
			30	...	4.30	18	...	4.61	4	...	11.6
			29	...	4.45	16	...	5.19			
			28	...	4.61	14	...	5.93			
			27	...	4.78						
			26	...	4.96						
			25	...	5.16						
			24	...	5.38						
			23	...	5.61						

★ Sheave Ratios in bold face type are speed increasing combinations.

Falk V-Belt Guards, built for maximum safety and serviceability.

Falk V-belt guards offer more than just compliance with OSHA requirements. For one thing, they're available at a low initial cost. For another, their practical construction makes them extremely user-friendly. You can quickly install them using easy-to-mount brackets. And since these covers are easy-to-remove and lightweight, they simplify field service of belt drives.

V-belt Guards are available in sizes to fit most Quadrive/V-belt combinations, or be used with other Falk drives. They come in an expanded metal cover, with a safety-yellow paint finish. Falk V-belt guards — easily installed, easily removed.



Guard/Hardware Selection Procedure

1) Using Table 13 and known belt drive information, determine which guards are suitable.

For overall guard dimensions, refer to Table 19.

TABLE 13 — Standard V-Belt Guard Selection — Inches ‡

Selection Parameter	GUARD SIZE †							
	14E	15E, 15F	16E, 16F	17E, 17F	18E	19E, 19F	20E, 20F	21E, 21F
Center Distance (Minimum)	21.00	22.00	27.00	29.00	34.00	34.00	32.00	42.50
Center Distance (Maximum)	28.00	29.00	34.00	36.00	42.00	42.00	42.00	56.00
Maximum Driver Shaft Diameter ★	3.50	3.50	3.50	3.50	3.50	3.50	3.50	3.50
Maximum Driven Shaft Diameter	2.00	2.25	2.25	2.25	3.00	3.00	3.00	3.00
Maximum Driver Sheave Diameter	6.50	8.00	8.00	10.00	10.00	12.00	12.00	14.00
Maximum Driven Sheave Diameter	8.00	14.00	14.00	15.00	15.00	20.00	28.00	32.00
Maximum Sheave Width	4.00	5.00	5.00	5.00	8.25	8.25	8.25	8.50

★ Maximum driver is a size 449T NEMA frame.

† E = Expanded metal covers (without fans).

F = For drives with shaft driven fans.

‡ Table allows for 3.5" of belt take-up adjustment.

2) Determine availability of mounting hardware:

Is guard for use with Falk Quadrive?

YES NO

↓ Will standard Quadrive motor mount be used? →

YES NO

↓ Are standard mounting brackets available (See Table 14)? →

TABLE 14 — Mounting Bracket Availability

GUARD SIZE	DRIVE SIZE										
	5107	5115	5203	5207	5215	5307	5315	5407	5415	5507	5608
14E	OK	OK	OK	OK	OK						
15E	OK	OK	OK	OK	OK						
16E		OK	OK	OK	OK	OK	OK				
17E			OK	OK	OK	OK	OK				
18E					OK	OK	OK	OK	OK	OK	
19E						OK	OK	OK	OK	OK	
20E								OK	OK	OK	OK
21E											OK
15F					OK	OK	OK				
16F					OK	OK	OK				
17F					OK	OK	OK				
19F					OK	OK	OK	OK	OK	OK	
20F								OK	OK	OK	OK
21F											OK

YES NO

↓ Supply guard complete with guard mounting brackets. See Table 15 for part numbers of drive w/o shaft fan. See Table 16 for part numbers of drive with shaft fan.

↓ Option 1: Supply guard only (Table 17) with loose strapping by Falk (Table 18). Falk will provide 4' of 12 gage strapping with sheet metal screws. Purchaser must cut, bend, drill, and mount.

Option 2; Supply guard on (Table 17). Purchaser is responsible for all mounting.

Guard Part Numbers

TABLE 15 — Part Numbers for Guards Including Quadrive Mounting Brackets – For Drives Without Fan

Expanded Metal Cover									
DRIVE SIZE	Motor Mount Position	14E	15E	16E	17E	18E	19E	20E	21E
5107	A6, B9, C12, D3	0783719	0783721
5115		0783723	0783725	0783727
5203		0783729	0783731	0783733	0783735
5207		0783737	0783739	0783741	0783743
5215		0783745	0783747	0783749	0783751	0783753
5307		0783755	0783757	0783759
5315		0783761	0783763	0783765
5407	A3, B6, C9, D12 A9, B12, C3, D6	0783768	0783772	0783776
	A6, B9, C12, D3	0783769	0783773	0783777
5415	A3, B6, C9, D12 A9, B12, C3, D6	0783780	0783784	0783788
	A6, B9, C12, D3	0783781	0783785	0783789
5507	A3, B6, C9, D12	0783792	0783796	0783800
	A9, B12, C3, D6	★	★	★
	A6, B9, C12, D3	0783793	0783797	0783801
5608	A3, B6, C9, D12 A9, B12, C3, D6	0786865	0786867
	A6, B9, C12, D3	0786866	0786868

TABLE 16 — Part Numbers for Guards Including Quadrive Mounting Brackets – For Drives With Fan

Expanded Metal Cover							
DRIVE SIZE	Motor Mount Position †	15F	16F	17F	19F	20F	21F
5215	A6, B9, C12, D3	0786869	0786870	0786871	0786872
5307		0786873	0786874	0786875
5315		0786876	0786877	0786878
5407	A3, B6, C9, D12 A9, B12, C3, D6 A6, B9, C12, D3	0786879	786880
5415	A3, B6, C9, D12	0786881	0786882
	A9, B12, C3, D6 A6, B9, C12, D3	0786883	0786884
5507	A3, B6, C9, D12	0786885	0786886
	A9, B12, C3, D6	★	★
	A6, B9, C12, D3	0786887	0786888
5608	A3, B6, C9, D12 A9, B12, C3, D6 A6, B9, C12, D3	0786889	0786890

★ Quadrive mounting brackets are not available for these assembly positions.

† Refer to Manual 377-820 & 377-822.

TABLE 17 — Part Numbers for Guard Only

With Expanded Metal Cover			
Size	Part Number	Size	Part Number
14E	0783803	...	See Table 16 (Guards not available without mounting brackets)
15E	0783805	15F	
16E	0783807	16F	
17E	0783809	17F	
18E	0783811	...	
19E	0783813	19F	
20E	0783815	20F	
21E	0786860	21F	

TABLE 18 — Options

Option	Part Number
Loose strapping & hardware (Purchaser to cut, bend, drill & mount)	0783816

Guard Dimensions

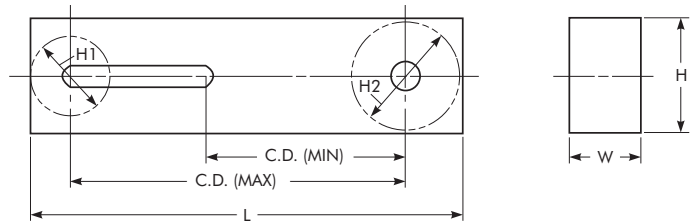

TABLE 19 — Standard V-Belt Guard Dimensions – Inches ‡

Dimension	GUARD SIZE							
	14E	15E, 15F	16E, 16F	17E, 17F	18E	19E, 19F	20E, 20F	21E, 21F
CD (Min)	21.00	22.00	27.00	29.00	34.00	34.00	32.00	42.50
CD (Max)	31.50	32.50	37.50	39.50	45.50	45.50	45.50	59.50
Driver Sheave Clearance (H1)	9.00	11.00	11.00	13.00	13.00	15.00	15.00	17.00
Driven Sheave Clearance (H2)	11.00	17.00	17.00	18.00	18.00	23.00	31.00	35.00
Width (W)	5.00	6.00	6.00	6.00	9.25	9.25	9.25	10.00
Height (H)	13.50	19.00	18.50	19.50	18.50	23.50	31.50	36.50
Length (L)	42.50	47.25	52.12	55.62	61.50	65.00	69.00	87.00
Approximate Weight – lb								
With Expanded Metal Cover	46	66	71	78	92	116	154	215

‡ All guards are 14 gauge steel.

Electric Fan Options/Dimensions – Inches ★

Sizes 5307 & 5315

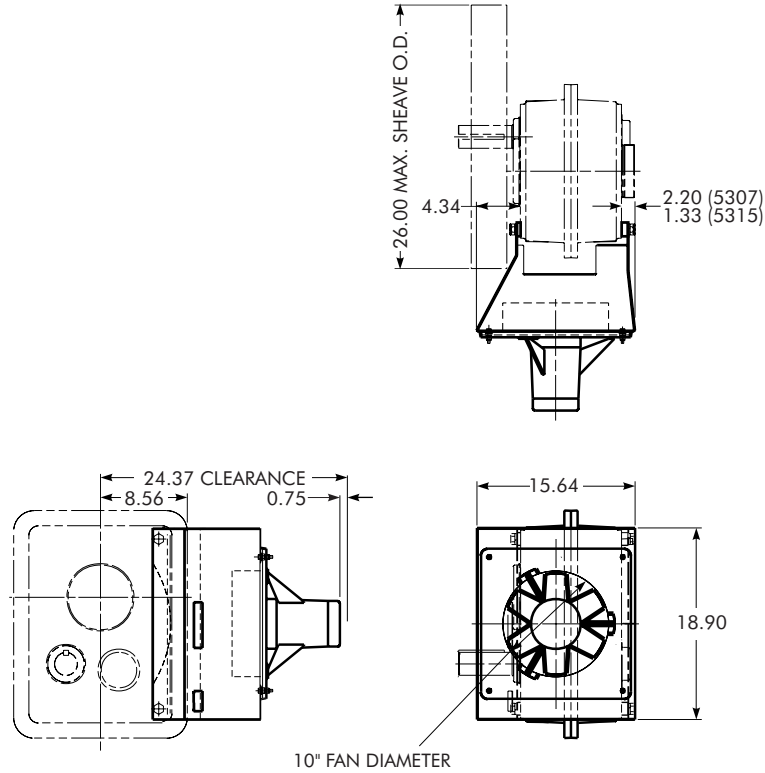

Electric Fan Kit	Fan Blade Diameter (Inches)	Electric Motor Specifications			Part No. †
		Volts	Phase	Hertz	
EFK5307J	10	110	1	60	0787260
		220	1	60	0787261
		220	1	50	0787262
		220/380	3	50	0787263
EFK5315J	10	110	1	60	0787264
		220	1	60	0787265
		220	1	50	0787266
		220/380	3	50	0787267

★ (See footnote on Page 17.)

† Includes fan, shroud and hardware (temperature switch not available).

Electric Fan Options/Dimensions – Inches ★

Sizes 5407 – 5608

ELECTRIC FAN, TEMP. SWITCH & BULB-WELL STANDARD LOCATIONS (BASED ON DRIVE MOUNTING POSITION)

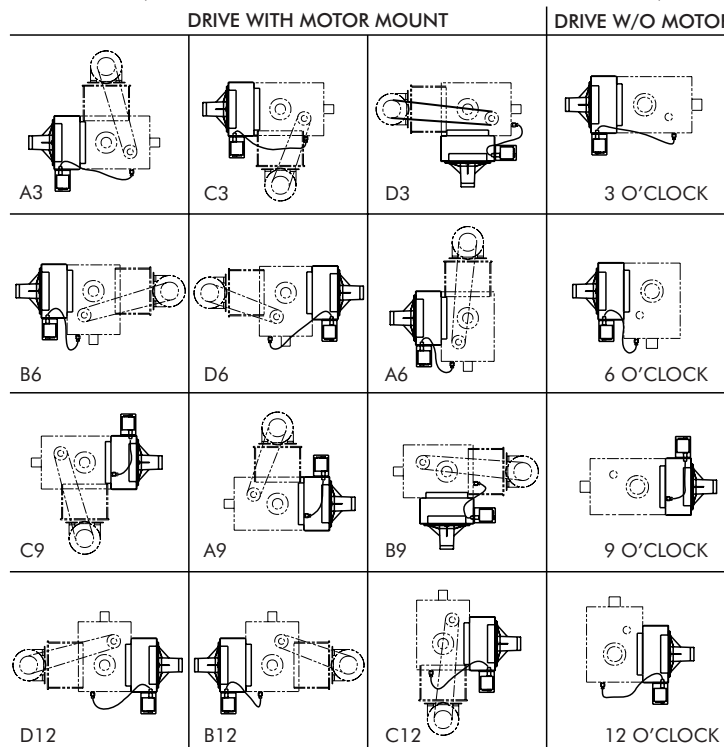

Electric Fan Kit	Fan Blade Diameter (Inches)	Electric Motor Specifications			Part No. †
		Volts	Phase	Hertz	
EFK5407J	10	110	1	60	0787268
		220	1	60	0787269
		220	1	50	0787270
		220/380	3	50	0787271
EFK5415J	12	110	1	60	0787272
		220	1	60	0787273
		220/380	3	60	0787274
		265/460	3	60	0787275
EFK5507J	12	220/380	3	50	0787276
		110	1	60	0787277
		220	1	60	0787278
		220/380	3	60	0787279
EFK5608J	12	265/460	3	60	0787280
		220/380	3	50	0787281
		110	1	60	0787282
		220	1	60	0787283
		220/380	3	60	0787284
		265/460	3	60	0787285
		220/380	3	50	0787286
		220/380	3	50	0787286

† Includes fan, shroud, temperature switch, and hardware.

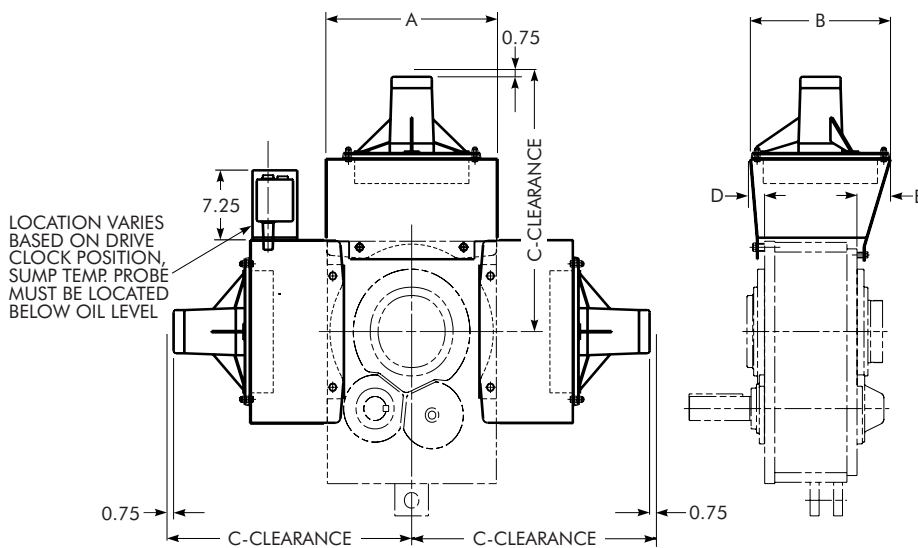

THE ELECTRIC FAN ACCESSORY CAN BE MOUNTED IN ANY OF THE POSITIONS SHOWN, BOTTOM AND SIDE OF THE DRIVE SUMP ARE THE PREFERRED LOCATIONS

ELECTRIC FAN SIZE ★	A	B	C	D	E
EF5407	19.20	15.70	30.00	1.60	5.80
EF5415	19.20	15.70	27.40	1.60	3.80
EF5507	22.40	15.70	28.60	1.40	3.60
EF5608	26.20	15.70	29.40	1.40	1.90

★ (See footnote on Page 17.)

Motor Mount Shaft Centers & Motor Frame Sizes

Introduction

The following supplements the data published on Pages 30 through 40. If shaft centers exceed the published maximum, refer complete data to Falk for engineering review.

Mounting Positions

The A3 assembly is the most common horizontal mounting position. However, the motor mount and drive may be mounted in any of the positions shown at the right. See Table 20 for center distance.

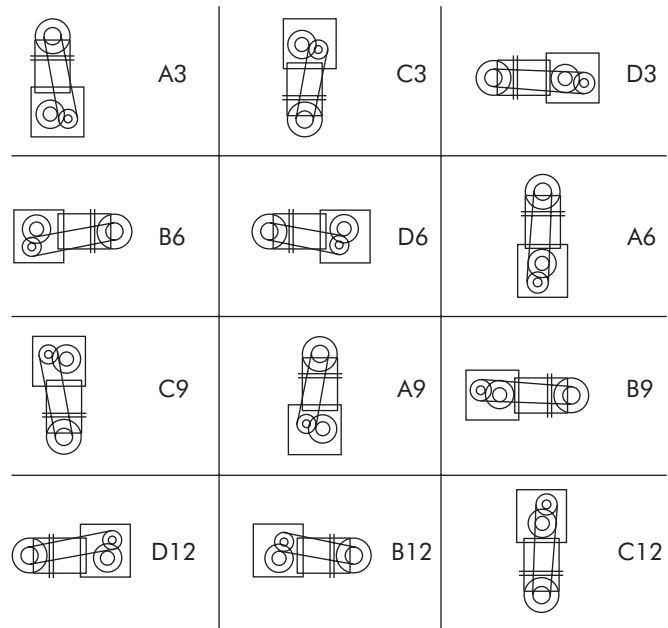

TABLE 20 — Motor-Drive Shaft Centers — Inches

Mounting Position	Motor Frame Size	56T, 143T, 145T	182T, 184T	213T, 215T	254T, 256T	284T, 286T	324T, 326T	364T, 365T	404T, 405T	444T, 445T, 447T, 449T
		Shaft Centers Min-Max								
A3 B6 C9 D12	MM5407-1	28.0-31.9	28.9-32.9	29.6-33.6	31.4-35.1	32.1-35.8	33.0-36.8	34.0-37.7	35.0-38.7	37.2-40.7
	MM5407-3	35.1-38.9	35.8-39.6	36.8-40.6	37.8-41.5	38.8-42.5	
	MM5407-4	
	MM5407-5	
	MM5415-1	29.5-33.2	30.4-34.2	31.2-34.9	
	MM5415-3	32.7-36.5	33.5-37.3	34.4-38.3	35.4-39.2	36.4-40.2	38.7-42.3
	MM5415-4	36.6-40.3	37.6-41.1	38.3-42.1	39.3-43.0	40.3-44.0	
	MM5415-5	
	MM5507-1	31.5-35.5	32.5-36.5	33.2-37.2	
	MM5507-3	34.9-38.7	35.7-39.4	36.6-40.4	37.6-41.4	38.6-42.4	
	MM5507-4	38.7-42.5	39.5-43.2	40.5-44.2	41.4-45.2	42.4-46.2	46.1-49.8
	MM5507-5	
MM5608-6	43.5-47.0	44.3-47.8	45.2-48.8	46.2-49.7	47.2-50.7		
MM5608-7	47.2-50.8	47.9-51.6	48.9-52.5	49.9-53.5	50.8-54.5	48.1-51.7	
C3 D6 A9 B12	MM5407-1	22.1-26.0	23.1-27.0	23.8-27.7	25.4-29.1	26.2-29.8	27.1-30.8	28.1-31.8	29.0-32.7	31.2-34.7
	MM5407-3	29.2-32.9	29.9-33.6	30.8-34.6	31.8-35.5	32.8-36.5	
	MM5407-4	
	MM5407-5	
	MM5415-1	21.7-25.6	22.7-26.5	23.4-27.0	
	MM5415-3	24.9-28.6	25.6-29.3	26.6-30.3	27.5-31.3	28.5-32.2	30.8-34.3
	MM5415-4	28.7-32.4	29.4-33.1	30.4-34.1	31.4-35.0	32.3-36.0	
	MM5415-5	
	MM5507-1	23.3-27.0	24.2-27.9	24.9-28.6	
	MM5507-3	26.4-29.9	27.1-30.6	28.0-31.6	28.9-32.5	29.9-33.4	
	MM5507-4	30.0-33.6	30.7-34.3	31.6-35.2	32.5-36.2	33.4-37.1	37.1-40.7
	MM5507-5	
MM5608-6	33.0-36.4	33.7-37.1	34.6-38.1	35.6-39.0	36.5-40.0		
MM5608-7	36.5-40.1	37.2-40.9	38.2-41.8	39.2-42.8	40.1-43.8	37.5-41.0	
D3 A6 B9 C12	MM5407-1	31.8-35.9	32.8-36.9	33.6-37.7	35.3-39.2	36.1-39.9	37.1-40.9	38.1-41.9	39.1-42.9	41.4-45.0
	MM5407-3	39.2-43.0	40.0-43.8	41.0-44.8	41.9-45.8	42.9-46.7	
	MM5407-4	
	MM5407-5	
	MM5415-1	32.6-36.6	33.6-37.6	34.3-38.3	
	MM5415-3	35.9-39.8	36.7-40.5	37.6-41.5	38.6-42.5	39.6-43.5	42.0-45.6
	MM5415-4	39.9-43.7	40.6-44.4	41.6-45.4	42.6-46.4	43.6-47.4	
	MM5415-5	
	MM5507-1	35.6-39.6	36.5-40.5	37.3-41.3	
	MM5507-3	39.0-42.8	39.7-43.5	40.7-44.5	41.7-45.5	42.7-46.5	
	MM5507-4	42.8-46.6	43.5-47.3	44.5-48.3	45.5-49.3	46.5-50.3	50.3-53.9
	MM5507-5	
MM5608-6	47.7-51.3	48.4-52.0	49.4-53.0	50.4-54.0	51.4-55.0		
MM5608-7	51.4-55.1	52.1-55.9	53.1-56.9	54.1-57.9	55.1-58.9	52.4-56.0	

Accessories/Options

Shim Blocks – Inches

Shim Block		Part Number		
No.	Thickness	56-215T	254-365T	404-449T
X ½	0.5	0711640	0711645	0759948
X 1	1.0	0711643	0745025	0759949
X 1½	1.5	0709360	0709361	0709363

SHIM BLOCKS – ALL SIZES — Shim blocks are available (at no extra charge when ordered with the Motor Mount) to increase the shaft centers up to 1½" as shown. Specify thickness required when ordering motor mount. These may be used with either the short center low bases or the long center high bases to assist in matching the shaft centers to the available V-belt centers. Please specify size shim block required; X½, X1 or X1½.

TA Removal Tool

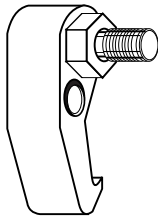

RT5107-5315J PN 0769406
Wt. 8 lb.
(Tool with 5 adapters and case)

RT5407-5608J PN 0769407
Wt. 10 lb.
(Tool with 2 adapters and case)

Thrust Plate Kits for JF Drives Utilizing TA Taper Bushing †

DRIVE SIZE	Description *	Part No.
5107	TP5107JF	0778773
5115	TP5115JF	0778774
5203	TP5203JF	0778775
5207	TP5207JF	0778776
5215	TP5215JF	0778777
5307	TP5307JF	0778778
5315	TP5315JF	0778779
5407	TP5407JF	0778780
5415	TP5415JF	0778781
5507	TP5507JF	0778782
5608	TP5608JF	0778783

† Refer to Manual 377-142(5107JF thru 5315JF) or 377-144(5407JF thru 5608JF).

* Kit consists of: Thrust plate, thrust plate fastener, hollow shaft retaining ring and drive shaft retaining ring.

AGMA Size Comparison

Max Bore (in)	AGMA	Falk		Browning	Dodge		Sumitomo/Fenner	Link Belt	Dorris
		4000J	5000J		TXT	TAII			
1 7/16	107	4107J	5107J	107SMT	TXT1	TA0107	107 C	107FX	107TR
1 15/16	115	4115J	5115J	115SMT	TXT2	TA2115	115 D	115FX	115TR
2 3/16	203	4203J	5203J	203SMT	TXT3	TA3203	203 E	203FX	203TR
2 7/16	207	4207J	5207J	207SMT	TXT4	TA4207	207 F	207FX	207TR
2 15/16	215	4215J	5215J	215SMT	TXT5	TA5215	215 G	215FX	215TR
3 7/16	307	4307J	5307J	307SMT	TXT6	TA6307	307 H	307FX	307TR
3 15/16	315	4315J	5315J	315SMT	TXT7	TA7315	315 J	315FX	315TR
4 7/16	407	4407J	5407J	407SMT	TXT8	TA8407	407 S	407FX	407TR
4 15/16	415	4415J	5415J	415SMT	TXT9	TA9415	415 K	415FX	415TR
5 7/16	507	4507J	5507J	507SMT	TXT10	TA10507	507 L	507D	507TR
6 1/2	608	4608J	5608J	608SMT	TXT12	TA12608	608 M	608D	608TR

For a competitive interchange, contact your Falk District Office or local authorized Falk Distributor.

Suggested Drive Arrangement When Falk Motor Mount Is Not Used

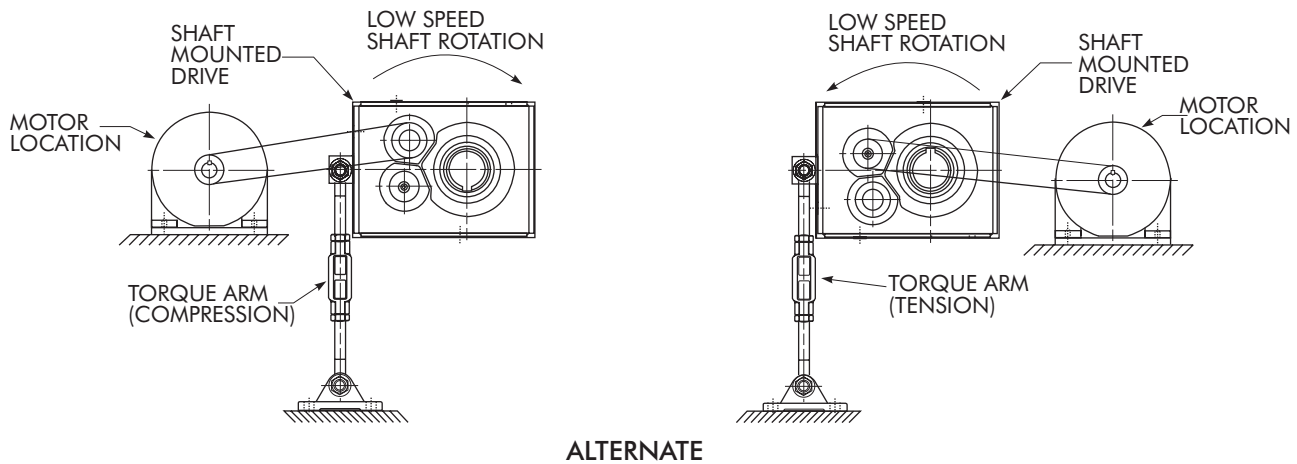
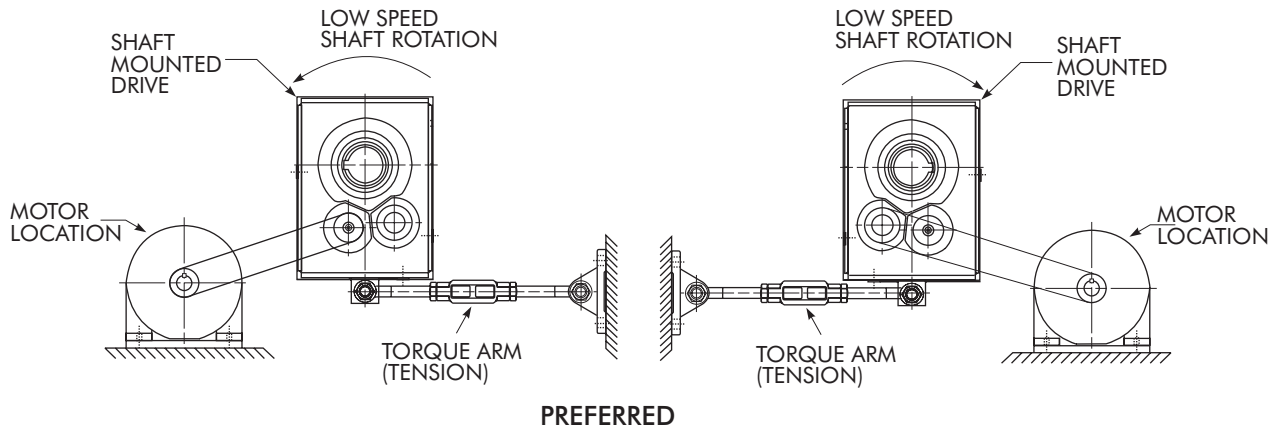

World Class Customer Service

For more than 100 years, the dedicated people of Rexnord have delivered excellence in quality and service to our customers around the globe. Rexnord is a trusted name when it comes to providing skillfully engineered products that improve productivity and efficiency for industrial applications worldwide. We are committed to exceeding customer expectations in every area of our business: product design, application engineering, operations, and customer service.

Because of our customer focus, we are able to thoroughly understand the needs of your business and have the resources available to work closely with you to reduce maintenance costs, eliminate redundant inventories and prevent equipment down time.

Rexnord represents the most comprehensive portfolio of power transmission and conveying components in the world with the brands you know and trust.

Quadrive, Renew, Omnibox, Ultramite, Steelflex, Rexnord, and Lifelign are registered trademarks of Rexnord Industries, LLC. Falk is a trademark of Rexnord. All rights reserved.

WORLDWIDE CUSTOMER SERVICE

AUSTRALIA

Rexnord Australia Pty. Ltd.
Picton, New South Wales
Phone: 61-2-4677-3811
Fax: 61-2-4677-3812

BRAZIL

Rexnord Correntes Ltda.
Sao Leopoldo - RS
Phone: 55-51-579-8022
Fax: 55-51-579-8029

CANADA

Rexnord Canada Ltd.
Scarborough, Ontario
Phone: 1-416-297-6868
Fax: 1-416-297-6873

CHINA

Rexnord China
Shanghai, China
Phone: 86-21-62701942
Fax: 86-21-62701943

EUROPE

Rexnord NV/SA
Mechelen, Belgium
Phone: 32-15-443811
Fax: 32-15-443860

Rexnord Kette GmbH
Betzdorf, Germany
Phone: 49-2741-2840
Fax: 49-2741-284-385

LATIN AMERICA

Rexnord International, Inc.
Milwaukee, Wisconsin
Phone: 1-414-643-2366
Fax: 1-414-643-3222
E-mail: international2@rexnord.com

MEXICO

Rexnord S.A. de C.V.
Queretaro, Qro.
Phone: 52-442-218.5000
Fax: 52-.442-218-1090

SINGAPORE

Rexnord International, Inc.
Singapore City, Singapore
Phone: 65-6338-5622
Fax: 65-6338-5422

UNITED STATES

Customer Service
Phone: 1-866-REXNORD
(1-866-739-6673)
Fax: 1-614-675-1898
E-mail: [rexnordcs\(state\)@rexnord.com](mailto:rexnordcs(state)@rexnord.com)
Example: rexnordcsohio@rexnord.com

ALL COUNTRIES NOT LISTED

Rexnord International
Milwaukee, Wisconsin
Phone: 1-414-643-2366
Fax: 1-414-643-3222
E-mail: international1@rexnord.com

